

PROFILE

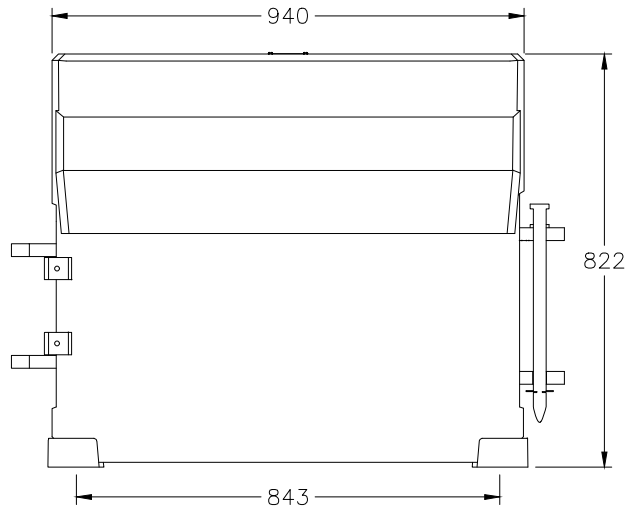

ELEVATION

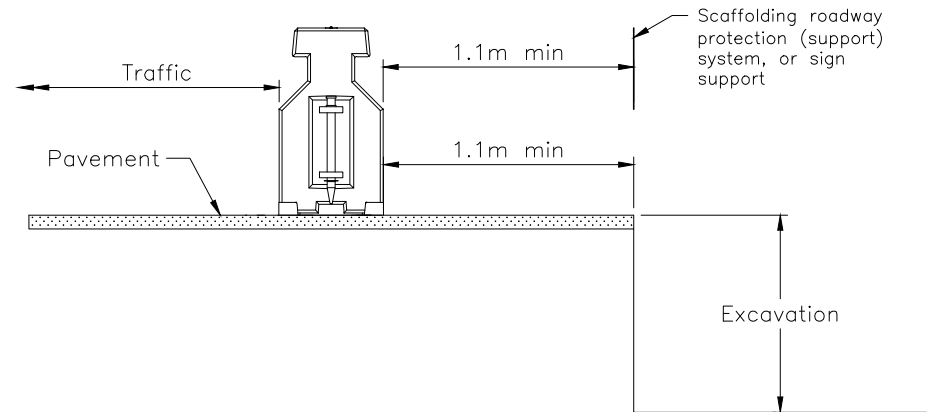

END VIEW

NOTES:

- A The system depicted here is a proprietary product.
- B System configuration meets AASHTO categories I, and II.
- C System configuration meets MTO deflection MASH TL-3.
- D All dimensions are in millimetres unless otherwise shown.

MINISTRY OF TRANSPORTATION ONTARIO DRAWING		August 2024	Rev	1
GUIDE RAIL SYSTEM, CONCRETE BARRIER CONCRETE REACTIVE TENSION SYSTEM		-----		

		MTOD - 911.640		