

5. Roadside Safety Hardware for Work Zones

For construction work zones where it has been determined that temporary barrier systems are required to provide positive protection between vehicular traffic and the work area and workers, this chapter lists, describes, and provides design guidance for installation of acceptable temporary barrier systems for use on provincial highway projects. Installation and use of these temporary systems also need to comply with guidance provided in OTM Book 7 and according to the Ontario Occupational Health and Safety Act. Temporary barrier systems are also used to separate opposing directions of traffic in detours within work zones.

The work zone systems listed in this chapter are complete as of the time of issue of this manual. New systems are often accepted for use on provincial highways between publications of the manual and designers are encouraged to keep informed of the most current version of all standards specifications, special provisions, standard drawings and policy memoranda pertaining to work zone hardware.

5.1 Temporary Barrier System Performance

The performance of temporary barrier systems is dependent on the design, installation, maintenance, and post-impact repair. Associated grading and appropriate terminals, leaving ends, or anchorage requirements, should be provided for each specific temporary barrier system in order for the barrier system to perform as designed and crash tested.

In order to be effective, a temporary barrier system should be capable of restraining a selected design vehicle under specified impact conditions (design vehicle of a particular size range, at a given speed and angle of impact). A temporary barrier system should prevent the selected design vehicle from the following:

- penetrating,
- vaulting over (over-riding), or
- wedging under (under-riding) the installation.

Unless otherwise designed, the temporary barrier system should remain substantially intact so that system elements and debris will not pose an undue risk to occupants in the impacting vehicle, other traffic, and workers in the work area. The temporary barrier system should be designed and installed to reduce the risk of spearing an impacting vehicle. A vehicle-barrier system collision should result in redirection of the impacting vehicle at a low departure angle

that will minimize the risk of interacting with other vehicles. Finally, the collision should not result in excessive lateral or longitudinal deceleration of the vehicle's occupants.

Temporary construction barrier (TCB) systems, should be of sufficient length and be properly terminated and anchored. In the case of freestanding TCB systems (e.g., no restraint system), sufficient length, and mass are necessary to prevent the system from being displaced significantly upon impact.

Since the dynamics of a collision are complex, the most effective means of assessing barrier system performance is through full-scale crash testing. By standardizing such tests, barrier system designers can compare the relative safety performance of alternative systems. As noted elsewhere in this manual, MTO has started to implement installations of new temporary and permanent roadside safety hardware on provincial highways that meets the crash test and evaluation criteria contained in the AASHTO Manual for Assessing Safety Hardware (MASH (2009 or 2016)).

Dynamic deflection is the maximum distance that the barrier system is expected to deflect laterally under a specified design impact, measured from the ~~front~~traffic face of the system. Working width is the distance between the traffic face of the system before impact in accordance with a specified crash test and the maximum lateral position of any major part of the system or vehicle after the crash test.

Temporary construction barriers should be installed, maintained, and inspected to ensure their condition reflects the as-tested configuration and adheres to manufacturer's requirements. Failure to comply with the nature in which these systems were tested can result in failure which could lead to serious injury or fatality of vehicle occupants.

Installation, maintenance and inspection of temporary construction barriers should be performed by persons with manufacturer-accredited training in these activities.

5.1.1 Temporary Construction Barrier Systems

Temporary barrier systems are devices that provide a physical limitation through which a vehicle would not normally pass (O-Reg 213/91, s. 67 (1)). In 2008, MTO implemented and started to phase in acceptance of alternative temporary concrete barrier systems and restraint systems that met the crash test acceptance requirements of NCHRP Report 350 TL-3. In 2013, MTO discontinued acceptance of Type I (I-Lock) temporary concrete barrier on new provincial highway contracts for installations on high speed roadways with posted speeds of 70 km/h and greater and in 2019 it was discontinued for all provincial highway contracts. Type I temporary concrete barrier had been used on MTO projects since the late 1980s when it was implemented to replace temporary concrete barrier with concrete keys or single hook connections. Starting in 2010, MTO started to implement and phase in TCB systems that met MASH TL-3.

Temporary barrier systems are designed and crash tested for use in construction work zones to provide physical separation between motorists and certain long term work zone operations and workers. There are four types of temporary barrier system that have been used successfully on provincial highway projects:

- Temporary Concrete Barrier;
- Moveable Temporary Concrete Barrier;
- Temporary Steel Barrier; and
- Temporary Type M Steel Beam Guide Rail.

To date on most provincial highway projects across the province, TCB systems have been specified and installed in work zones on paved surfaces. TCB is usually used on multi-staged projects where they are subsequently relocated elsewhere within the project for other construction stages. On some recent projects, temporary Type M Steel Beam Guide Rail (SBGR) systems have been used for installations on granular roadway surfaces. On several projects, Temporary Type M SBGR was specified for the first stage, and subsequently removed, salvaged, and reinstalled for a subsequent stage, and then finally, removed, salvaged and reinstalled as part of the permanent roadside barrier system on the project.

Temporary barrier systems are usually owned by the contractor and used in temporary work zones to separate vehicular traffic from work areas and workers. In certain constrained work zones and work operations, ~~quickchange~~-movable temporary concrete barrier systems may be advantageous for daily adjustments to the width of the travelled way (number of traffic lanes open to traffic) and the width of the work zone and offset to work zone operations.

Dynamic deflection is an important consideration when selecting the appropriate type of temporary barrier system. Barrier mass, length and connection type affect the performance of the system including dynamic deflection of the system during vehicular impacts.

Considerations such as speed of deployment and ease of relocation may play a significant part in the selection of the type of temporary barrier system best suited for a particular work zone and work zone operation to a particular application.

In May 2019, MTO updated the terminology to Temporary Construction Barrier (TCB) to allow for MASH tested Temporary Steel Barrier systems to be used at the option of the contractor on ministry contracts.

Four categories of Temporary Construction Barrier corresponding to the TL-3 dynamic deflection of each system are created as follows, and correspond to four tender items:

Category I: >1,500 mm

Category II: 1000 mm – 1500 mm

Category III: 500 mm – 999 mm

Category IV: <499 mm

The category that a barrier falls under is indicated in the construction specification and informs the contractor of the available choices for a given tender item. Barriers that satisfy a higher performance category may be used in lieu of a specified lower performance system, allowing greater on-site flexibility.

Designers are required to be aware of the distance from the edge of shoulder to the top of an excavation or to fixed objects such as bridge parapets, roadway protection or scaffolding when specifying a Temporary Construction Barrier item.

The creation of the deflection category system simplifies the process for adding or updating temporary barrier systems as a new system may simply be added to the list of available systems in the existing specification and categorized appropriately.

Designers shall only use temporary construction barriers listed in active specifications or special provisions and standard drawings, or those for which such documents have been issued by the Highway Design Office on a contract-specific basis. This requirement applies to all design-bid-build, design-build, P3, CMCG and all other alternative delivery model contracts. This requirement also applies to use of temporary construction barrier on municipal roads crossing provincial highways either at-grade or grade-separated.

Systems shall not be modified from the configurations shown in the standards. Highway Design Office shall be contacted for guidance in case site-specific constraints preclude the use of work zone hardware in its standard configuration.

5.1.1.1 Use of TCB's to Separate Opposing Traffic Flows

Many staged freeway construction contracts involve the temporary shifting of a narrow median centreline or the temporary reduction of traffic from two lanes in each direction on two separate platforms to one lane in each direction on a single platform through the construction of temporary median crossovers. In many cases, the use of temporary construction barriers to separate the two directions of high-speed, high-volume traffic provides a tangible safety benefit.

Desirably, a barrier should be provided such that the dynamic deflection is less than the offset of the traffic face of the barrier to the oncoming lane being protected.

It may not be absolutely necessary in all cases to provide a barrier that will not deflect into the adjacent oncoming lane based on its TL-3 working width. This is particularly true in cases where a barrier is used to separate parallel opposing single lanes of traffic as the odds of an impact with a speed and angle combination resembling those seen in crash testing are significantly diminished. Additional mitigating factors are the fact that vehicles don't occupy the entire width of a lane and drivers tend to keep a distance from barriers when driving parallel to them (see discussion on shy line in section 3.1.6). The use of a high-performance barrier such as Category IV may require the use of anchors which can add significant cost and construction time for what may be only marginal safety improvements.

At a minimum, in the context of the above consideration, a barrier one deflection category lower may be considered where they are used to separate single opposing lanes of traffic.

TL-5 temporary barrier should desirably be used when separating multiple adjacent opposing through lanes (3 or more in one or both directions) as impact speed and angle combinations may be higher. TL-3 Category IV barriers should be used as a minimum in these instances.

Where traffic volumes are sufficiently low, delineation using pavement markings and delineator posts may also be considered as a means of separating temporary opposing single-lane traffic flows.

A degree of designer judgement is encouraged when considering the use of TCB's to separate opposing traffic flows during construction. Highway Design Office may be contacted during design of such installations for additional guidance.

Where restrained barriers are used to separate opposing flows of traffic, those with symmetrical restraint configurations must be used. Barriers with anchors only on the traffic side are only crash tested for impacts on that side and may not perform predictably if impacted on the non-pinned side.

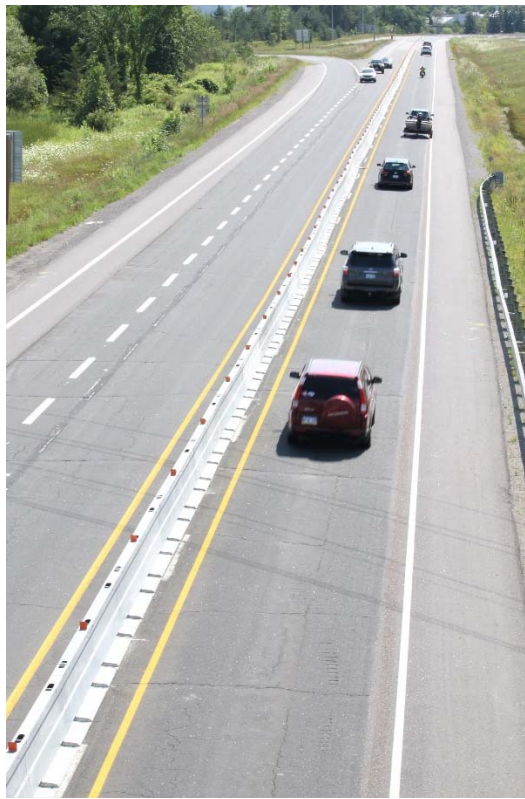

Figure 5-1: Category IV Barrier Separating Staged Opposing Freeway Traffic

5.1.2 Temporary Concrete Barrier Systems

The following temporary barrier systems are accepted for use on provincial highway projects according to applicable standards active in the Contract Preparation System:

- Type J;
- Type M;
- Type T;
- Type X; ~~and~~
- Type Z; and
- ReBloc TL-5

Temporary Concrete Barrier is a portable barrier system consisting of free-standing precast concrete segments that are positively connected together to form a continuous barrier system. Descriptions of the various types of TCB systems accepted for use and specified on provincial highway projects are described in this chapter.

In 2008, the ministry implemented two new temporary concrete barrier designs that met the crash test acceptance requirements of NCHRP Report 350 at TL-3. This included temporary concrete barriers with Type J and Type M connections.

In 2008 it was also announced that temporary concrete barrier with I-Lock connections will be discontinued on ministry contracts awarded after December 13, 2013 for installations on high speed roadways. The ministry also agreed in 2008 to continue to accept I-Lock temporary concrete barrier on low speed roadways with posted speeds less than 70 km/h. I-lock barrier was removed from the ministry's specification after the conversion to Temporary Construction Barrier.

In 2010, MTO began to specify temporary concrete barrier with Type T connections which met NCHRP Report 350 TL-3. In 2010, the Type T temporary concrete barrier design was modified and then successfully crash tested in accordance with MASH TL-3.

In 2015, MTO started to specify Type X temporary concrete barrier for use on bridge decks where minimal deflection was required and bolting into the bridge deck was not acceptable.

Currently Type X temporary concrete barrier is the only unrestrained concrete or steel system that is acceptable for Category III.

Each installation of temporary concrete barrier less than 100 m in length should consist of units having the same type of temporary concrete barrier connection. For installations longer than 100 m in length, it is acceptable to transition from one type of temporary concrete barrier connection to another type of temporary concrete barrier connection by use of a three beam rail connections across the front and back side of the barrier connections.

There are not currently standards for transitions between temporary concrete barrier and temporary steel barrier or between two different temporary steel barrier systems. ~~Design and Contract Standards~~Highway Design Office should be contacted if such connections are proposed.

Precast Ontario Tall Wall barrier segments with I-Lock connections should not be used as a temporary concrete barrier on construction sites. These barriers have not been crash tested in a freestanding configuration and are not compatible with standard temporary crash cushions.

Advantages and Disadvantages:

The advantages of temporary concrete barrier are:

- Cost of installation is relatively inexpensive compared to other temporary barrier systems;
- Can be used on horizontal curves with radius of 45 m or greater; and
- Can be connected to permanent concrete barriers and concrete bridge rails.

The disadvantages of temporary concrete barrier are:

- Size and mass make them expensive for remote locations;
- Heavy to move, transport and unload at work site; and
- Need to be placed on paved surfaces.

5.1.2.1 Type J Temporary Concrete Barrier:

Type J TCB is a proprietary precast concrete barrier developed by Easi-Set Industries Inc. using patented J-J hook connections that meets MASH TL-3. The version precast in Ontario has a New Jersey shape that is identical in shape to the I-Lock TCB except that the lower vertical face has been increased in height to 75 mm. The height of the Type J temporary concrete barrier is 900 mm, with a width of 630 mm at the bottom and 165 mm at the top. The standard lengths being produced in Ontario are 4m and 6m. Adjacent segments are connected together by the steel J-J hooks that are cast into the ends of each segment. The J-J hooks slide together to form a positive connection. The system may be installed on horizontal curves with radii as sharp as 31 m with the 4 m units, and 47 m with the 6 m units. Additional details are provided in Figure 5-12.

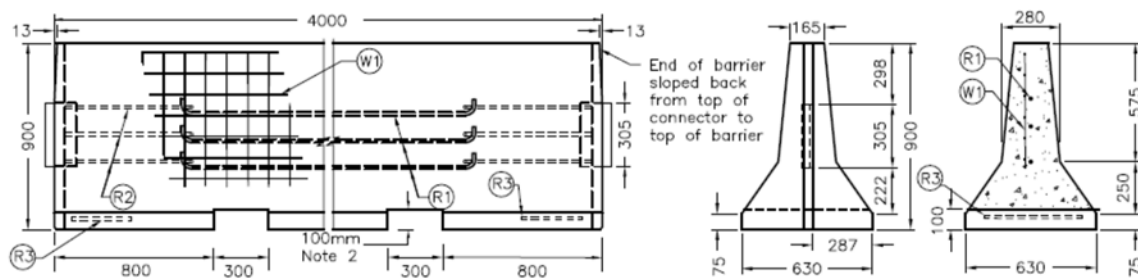

Figure 5-12: Type J Temporary Concrete Barrier

5.1.2.2 Type M Temporary Concrete Barrier:

Type M temporary concrete barrier is a non-proprietary precast concrete barrier that was developed by Midwest Roadside Safety Facility (MwRSF) that meets [NCHRP Report 350 MASH TL-3](#). It has a modified safety shape design with a height of 815 mm, width of 585mm at the bottom and 205mm at the top. The standard length being produced in Ontario is 3805 mm with 92mm gaps between each barrier unit for the pin and loop connections, resulting in an effective length of 3897mm. Connections consist of a 32mm diameter A36 steel pin placed down through six steel loops (three per side). [Type M temporary concrete barrier anchored to concrete pavement or bridge decks has been successfully crash tested according to MASH. Restraint systems for Type M temporary concrete barrier consisting of steel pinned installations through 50mm of asphalt, strapped to concrete, and bolted to concrete designs have also been successfully crash tested according to NCHRP Report 350 TL-3. The restrained system was crash tested at a particular offset to a vertical drop off. When impacted, the restrained barriers cantilevered over the edge but were still able to contain and redirect the impacting vehicle. As such, minimum offsets to excavation edges are different than minimum offsets to obstacles on standard drawings.](#) The system may be installed on horizontal curves with radii as sharp as 26 m. Additional details are provided in Figure 5-~~23~~. Restraint system details are provided on the applicable standards active in MTO's Contract Preparation System.

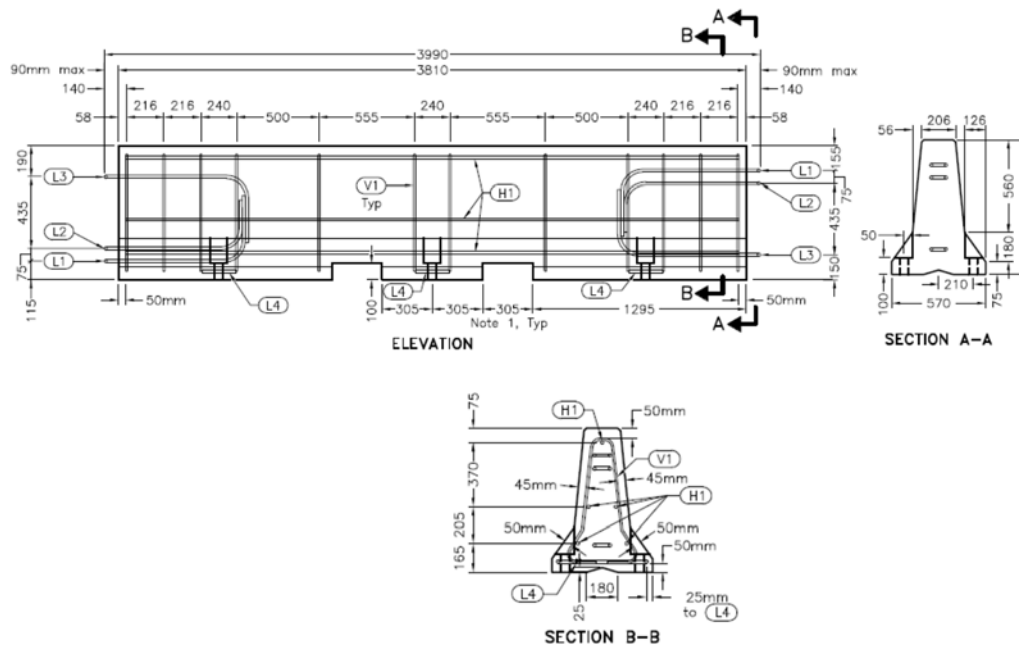
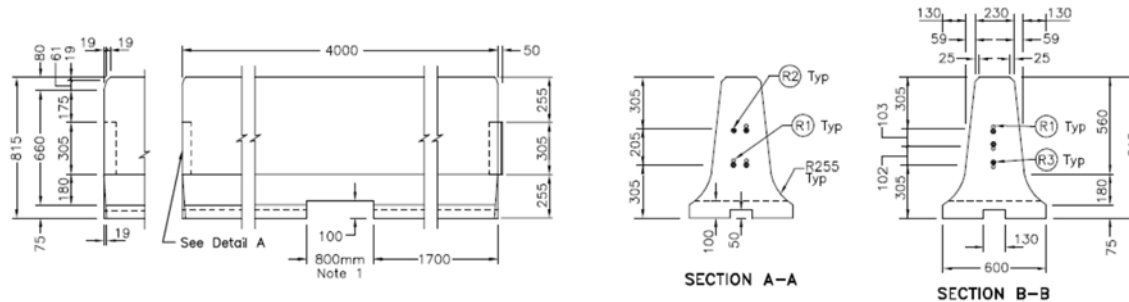

Figure 5-23: Type M Temporary Concrete Barrier

5.1.2.3 Type T Temporary Concrete Barrier:

Type T temporary concrete barrier is a proprietary barrier that was developed by Rockingham Precast Ltd. that meets MASH TL-3. It is an F-shape design with a height of 815 mm, width of 600 mm at the bottom and 230 mm at the top. The standard lengths being produced in Ontario are 4 m and 6 m. One end of each unit has a steel T-shape plate cast into one end of the barrier, and the opposite end has a slotted steel tube cast into the concrete. Connecting the barrier segments involves lowering units successively into place with the connections between the adjoining barriers engaged, forming a continuous wall. The system may be installed on

horizontal curves with radii as sharp as 26 m with the 4 m units, and 39 m with the 6 m units. Additional details are provided in Figure 5-34.



Figure

5-34: Type T Temporary Concrete Barrier

5.1.2.4 Type X Temporary Concrete Barrier:

Type X temporary concrete barrier is a non-proprietary precast concrete barrier that was developed by the Texas Transportation Institute (TTI) for Texas Department of Transportation that meets NCHRP Report 350 TL-3 and MASH TL-3. It has a F-shape design with a height of 815 mm, width of 600 mm at the bottom and 235 mm at the top. The standard lengths being produced in Ontario are 3 m, 6 m, and 9 m. Connections consist of two 22.2 mm diameter Grade B7 threaded cross bolts at each end. The system was developed for constrained work

zones where minimal dynamic deflection was desired. The 3 m version when crash tested according to MASH TL-3 (60 m installation length) reported 686 mm maximum dynamic deflection. The system may be installed on horizontal curves with radii as sharp as 38.1 m for 3 m units, and 122 m for 9 m units. Additional details are provided in Figure 5-45.

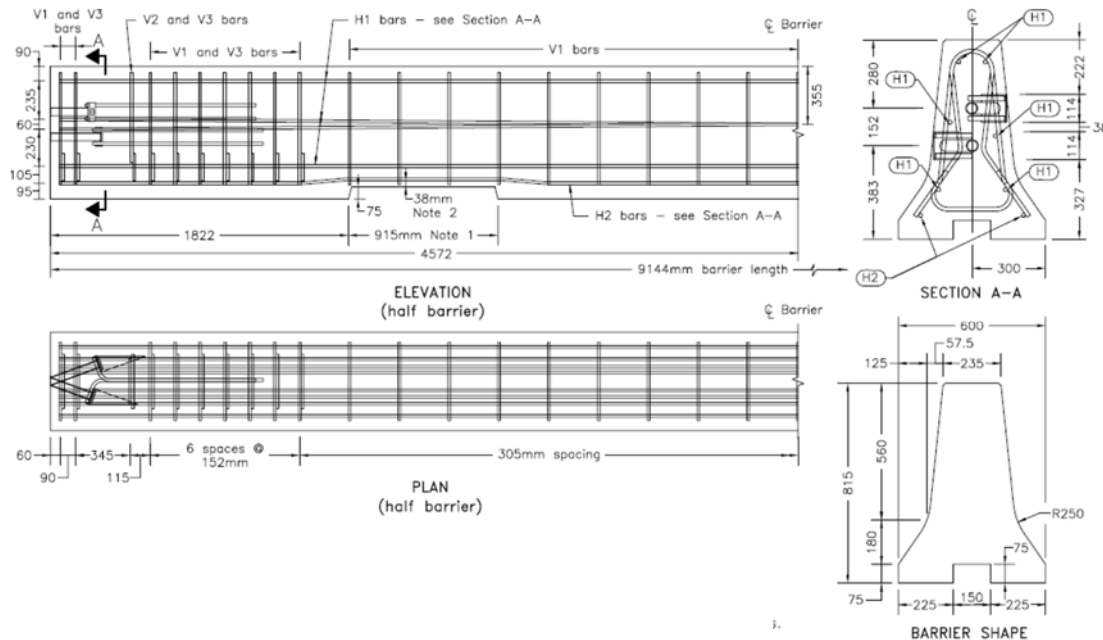

Figure 5-45: Type X Temporary Concrete Barrier

Type X barrier may also be anchored. Anchoring of Type X barrier requires the use of 4 m barrier units with three recesses cast into the lower portion to allow for anchors to be installed into the pavement. All other aspects of the barrier are identical to the unrestrained versions. Restrained Type X requires the use of a proprietary ReDD insert placed into the recesses, through which the anchor is placed. Restrained Type X barrier is a very high performing system, with a MASH TL-3 dynamic deflection of 150 mm. Anchors are placed on only one side of the barrier which makes this variation unsuitable for separation of opposing traffic flows.

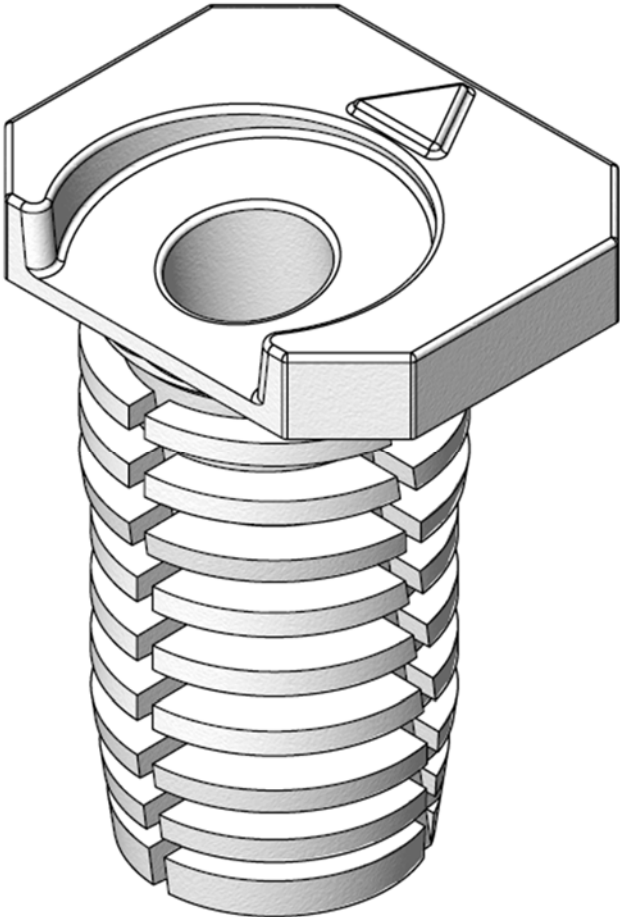

Figure 5-6: ReDD Insert for Type X Barrier

5.1.4.5 Type Z Temporary Concrete Barrier:

Type Z temporary concrete barrier stands for ZoneBloc - A proprietary narrow profile concrete barrier distributed by Hill & Smith Inc. The concrete longitudinal barrier system has been crash tested to AASHTO MASH TL-3. It has a cross section similar to an I-Beam with a height of 800 mm, width of 300 mm at the bottom, 180 mm at the top, and between 90 and 75 mm in the middle section. The system consists of 12m standard ZoneBloc barrier sections along with anchored terminal barrier at the approach and leaving ends of the installation. The ZoneBloc anchored terminal barrier allow transitioning from crash cushion to ZoneBloc, providing bidirectional approach and leaving ends if required. The barriers are connecting with proprietary tension links that result in a 1150 mm dynamic deflection when tested to MASH TL-3. Connecting the barrier segments involves lowering units successively into place with the connections between adjoining barriers engaged, forming a continuous wall. The barrier rest on rubber pads to minimize damage to the road surface. The system may be installed on horizontal curves with radii as sharp as 260 m.

The Zonebloc's narrow base width of only 300 mm allows the longitudinal barrier system to have a narrow overall working width that is ideal for constrained work zones. Type Z Barrier has similar deflection characteristics to standard temporary concrete barrier, but with half the average barrier width.

Type Z barrier may also be restrained. Restrained Type Z barrier uses the same 12 m barrier unit length as the unrestrained version with the exception of eight recesses cast into the lower portion to allow for anchors to be installed into the pavement. The restrained Type Z is a very high-performance barrier with a MASH TL-3 dynamic deflection of approximately 300 mm. Anchoring is symmetrical which allows for this barrier to be used to separate opposing traffic flows.

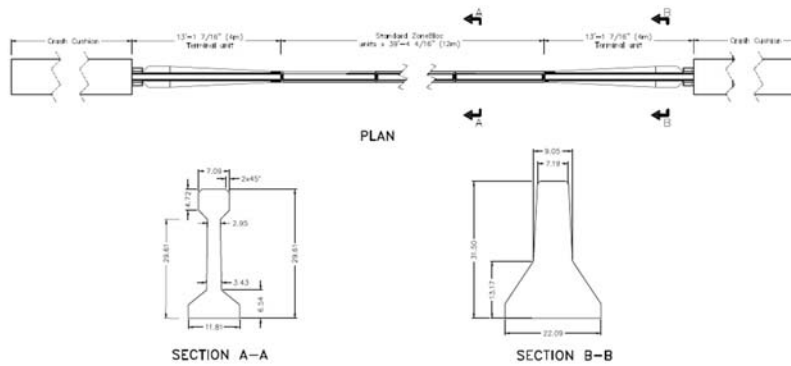

Figure 5-57: Type Z Temporary Concrete Barrier

Manufacturer: Hill and Smith
 Website: <https://hillandsmith.com/products/zonebloc>

5.1.3 Movable Temporary Concrete Barrier System

Where temporary barriers are required and lane closures are restricted to specific times of day, Movable Temporary Concrete Barrier (MTCB) should be used.

5.1.3.1 Quickchange Moveable Barrier

The Quickchange Moveable Barrier (QMB) System is a proprietary movable temporary concrete barrier system that meets NCHRP Report 350 TL-3. The system consists of one metre long free-standing, heavily reinforced, precast concrete barrier segments that compatible with specialized barrier transfer machine as shown in Figure 5-68. The connected barrier segments can be shifted laterally by one lane-width in a single pass of the equipment.



Figure 5-68: Quickchange Moveable Barrier Transfer Machine Shifting QMB Barrier

The QMB concrete segments are heavily steel reinforced and measure 815 mm tall by 610 mm wide, and 1.0 m in length with a steel hinge connection. Additional details are provided in Figure 5-97.

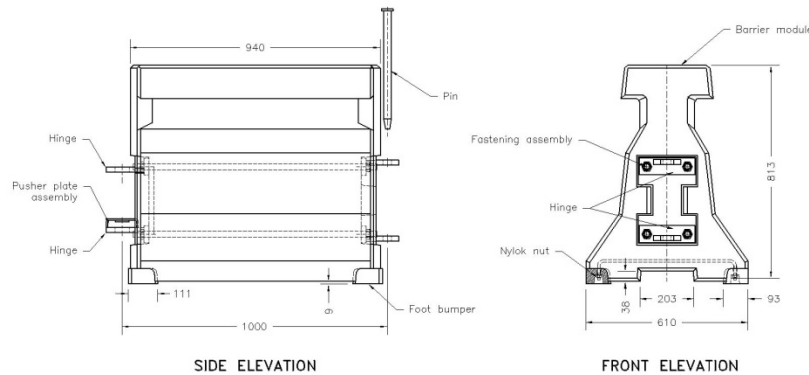

Figure 5-97: Quickchange Movable Barrier System

Manufacturer: Lindsay Corporation – Barrier Systems Inc.

Web Site: <http://www.barriersystemsinc.com/>

5.1.3.2 Reactive Tension System

The Reactive Tension System (RTS) is a proprietary movable temporary concrete barrier system that meets MASH TL-3. The system consists of one metre long free-standing, reinforced, precast concrete barrier segments that compatible with specialized barrier transfer machine as shown in Figure 5-10. The connected barrier segments can be shifted laterally by one lane-width in a single pass of the equipment.



Figure 5-10: Reactive Tension System Barrier
Photo Courtesy of Lindsay Transportation

The RTS concrete segments are steel reinforced and measure 822 mm tall by 457 mm wide, and 940 m in length with a steel hinge connection. Additional details are provided in Figure 5-11.

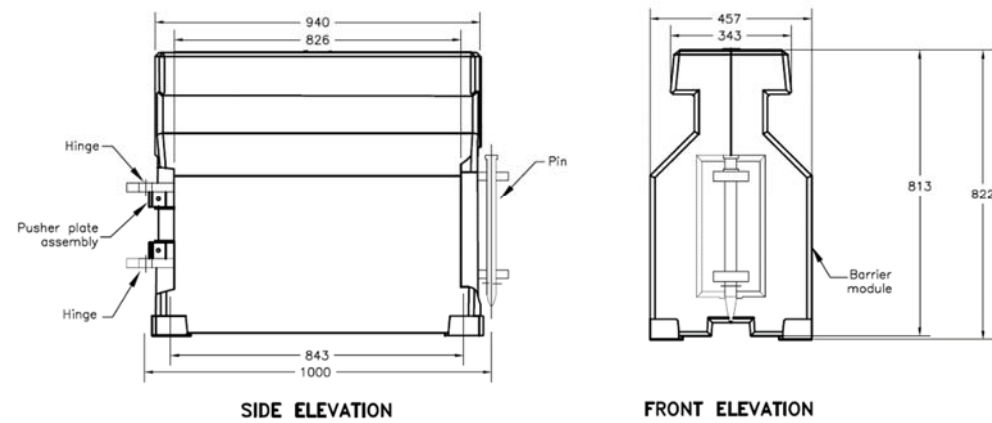

Figure 5-11: Reactive Tension System

Manufacturer: Lindsay Corporation

Web Site: <http://www.lindsay.com>

5.1.3.3 Flux Barrier

The FLUX barrier is a proprietary movable temporary concrete barrier system that meets MASH TL-3. The system consists of one metre long free-standing, heavily reinforced, precast concrete barrier segments that compatible with specialized barrier transfer machine as shown in Figure 5-12. The connected barrier segments can be shifted laterally by one lane-width in a single pass of the equipment.



Figure 5-12: FLUX barrier

The FLUX barrier segments are heavily steel reinforced and measure 864 mm tall by 457 mm wide, and 1.0 m in length with a steel hinge connection. Additional details are provided in Figure 5-13.

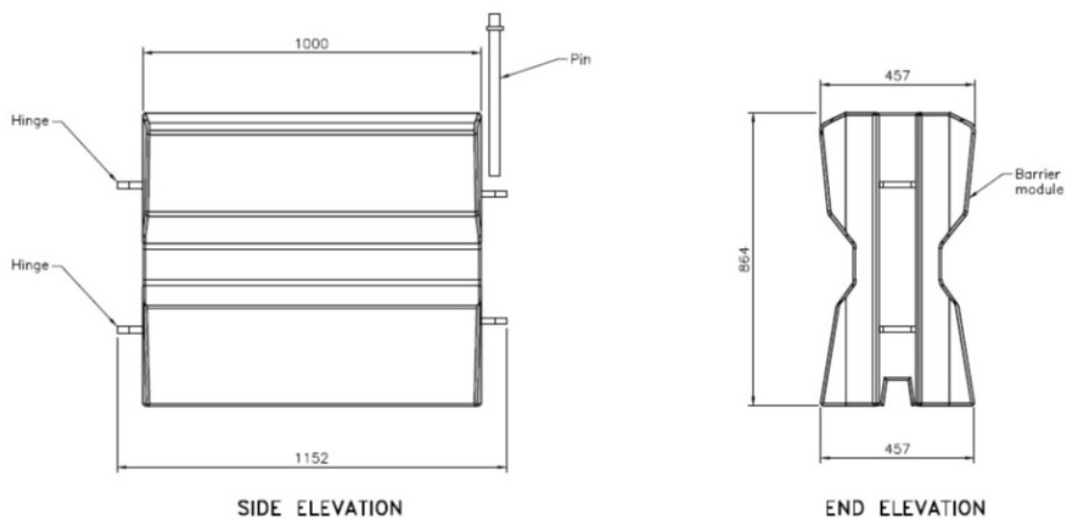

Figure 5-13: FLUX Barrier Dimensions

Manufacturer: Northern Infrastructure Products

Web Site: <http://northern-ip.com/flux-moveable-concrete-barrier>

5.1.4 Temporary Steel Barrier Systems

Temporary Steel Barriers (TSB) are portable barrier systems consisting of free-standing fabricated double sided steel barrier segments that are positively connected together to form a continuous barrier system. Descriptions of the various types of TSB that have been used on provincial highway projects as an alternative to temporary concrete barrier systems are provided on the following pages.

Advantages and Disadvantages:

The advantages of temporary steel barrier when compared to temporary concrete barrier are:

- Light weight and stackable;
- Larger quantities can be transported per truckload, and;
- Ideal option for bridges with weight restrictions

The disadvantages of temporary steel barrier when compared to temporary concrete barrier are:

- Systems need to be pinned at each end through pavement or concrete, and at specified intervals throughout the installation dependent on desired deflection requirements;
- More expensive to initially purchase than temporary concrete barrier; and
- Need to be placed on paved surfaces.

5.1.4.1 BarrierGuard 800:

BarrierGuard 800 is a proprietary TSB that meets NCHRP Report 350 TL-3. The system consists of galvanized steel segments with a height of 800 mm, width of 540 mm at the bottom and 230 mm at the top. It is available in segment lengths of 6 m and 12 m that weigh 90 kg per metre. Adjacent segments are connected together using male and female QuickMount connectors that lock into place.



Figure 5-148: BarrierGuard 800 Temporary Steel Barrier

The system is anchored at each end and at a point approximately 6 m in from each end with steel anchor rods. The system can also be configured to minimize deflection using additional steel anchors at specified intervals dependent on thickness of asphalt or concrete.

Manufacturer: Highway Care

Web Site: https://www.highwaycareint.com/product_info/44/barrierguard800

5.4.1.2 ZoneGuard[®]

ZoneGuard is a proprietary TSB that was developed by Hill and Smith Inc. that meets MASH TL-3. The system consists of galvanized steel segments with a height of 800 mm, width of 700 mm at the bottom, and 157 mm at the top. It is available in 15.24 m length segments weighing 1406 kg each (92 kg per meter). Adjacent segments are connected together by sliding the male end onto the female end and then sliding and bolting the engagement assembly into place at the top of the barrier.



Figure 5-159: ZoneGuard Temporary Steel Barrier Installation

Photo credit: Hill & Smith

The system is anchored using steel anchors at each end of the installation located 0.5 m and 5.1 m from the ends into asphalt or concrete. The system can also be configured to minimize deflection using additional steel anchors at specified intervals dependent on thickness of asphalt or concrete. The Minimum Deflection System additional anchors are spaced at a maximum of 10.2 m along the barriers installation length.

Manufacturer: Hill and Smith, Inc.

Web Site: <http://www.hillandsmith.com/zoneguard/>

5.1.4.3 Defender

The Defender is a proprietary TSB that meets MASH TL-3. The system consists of galvanized steel segments with a height of 800 mm, width of 680 mm at the bottom and 200 mm at the top. It is available in segment lengths of 3.9 m with a mass of 82 kg per metre. Adjacent segments are connected together using male and female sliding interlocking connectors and a joining pin.



Figure 5-160: Defender Barrier
Photo Courtesy of Safe Barriers

The system is anchored with 8 pins through each end unit and at 9.15m intervals on both sides of the barrier throughout the run. The system can also be configured to minimize deflection using additional steel anchors at specified intervals dependent on thickness of asphalt or concrete.

A High Containment version with reduced pin spacing is available that meets MASH TL-4. ~~Design and Contract Standards~~Highway Design Office shall be contacted for additional information on the use of this configuration.

Manufacturer: Safe Barriers

Web Site: <https://www.safebarriers.com/download-center/>

5.1.4.4 Safezone:

The Safezone is a proprietary TSB that meets MASH TL-3. The system consists of galvanized steel segments with a height of 806 mm, width of 454 mm at the bottom and 295 mm at the top. Inserts that slide through the bottom of the units to facilitate placement of anchor pins increase the effective bottom width to 639mm. It is available in segment lengths of 5.801 m with a mass of 86 kg per metre. Adjacent segments are connected together using male and female QuickLink connectors that lock into place and are secured with a bolt.

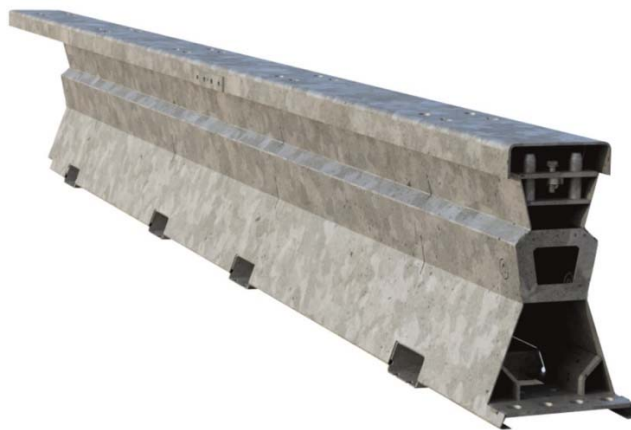

Figure 5-171: Safezone Barrier
Photo courtesy of Laura Metaal

The system is anchored at each end with 4 anchor pins. The standard installation does not use anchor pins along the run. A Limited Deflection configuration is available that utilized anchor pins along the run of barrier at a maximum spacing of 11.6m.

An alternative configuration that meets MASH TL-4 is also available. For use as a TL-4 barrier, contact ~~the Design and Contract Standards~~[Highway Design](#) Office for guidance.

Manufacturer: Laura Metaal

Web Site: <https://www.laurametaal.com/us/road-safety/temporary-barriers/safezone>

5.1.4.5 HV2

The HV2 is a proprietary TSB that meets MASH TL-4. The system consists of galvanized steel segments with internal concrete ballasting with a height of 900 mm, width of 450 mm at the bottom and 200 mm at the top. It is available in segment lengths of 5.845 m with a mass of 360 kg per metre. Adjacent segments are connected together using an interlocking joiner.



Figure 5-182: HV2 Barrier
Photo Courtesy of Safe Roads

The system is unique among steel barriers in that it does not require anchoring at the ends or along the run.

Although the system has been successfully crash tested to MASH TL-4 its TL-3 parameters are specified for ministry contracts. For use as a TL-4 barrier, contact ~~the Design and Contract Standards Highway Design~~ Office for guidance.

Manufacturer: Safe Roads

Web Site: <https://www.saferoads.com.au/hv2-barrier>

5.1.4.6 Highway Guard

The Highway Guard is a proprietary TSB that meets MASH TL-3. The system consists of galvanized steel segments with a height of 800 mm, width of 540 mm at the bottom and 250 mm at the top. It is available in segment lengths of 6 m with a mass of 92 kg per metre. Adjacent segments are connected together using a universal T-connector.



Figure 5-19: Highway Guard Barrier
Photo Courtesy of HighwayCare

The system is anchored using six steel mechanical or chemical anchors at each end of the installation located 1.0 m, 5.0 m and 7.0 m from the ends into asphalt or concrete. Intermediate anchors placed on both sides of the barrier are placed at three interval options. The Standard Deflection System requires intermediate anchors at an interval of 58 m and has a dynamic deflection of approximately 1.95 m. The Lowest Deflection System requires intermediate anchors at an interval of 12 m, staggered across the barrier connection and has a dynamic deflection of approximately 0.7 m. The Minimum Deflection System requires intermediate anchors at an interval of 6 m staggered across the barrier connection and has a dynamic deflection of approximately 0.5 m. Each anchoring variation of the Highway Guard has symmetrical anchoring and may be used to separate opposing traffic flows.

Manufacturer: Highway Care International

Website: <http://highwayguard.com>

5.1.5 Temporary Type M SBGR

Temporary Type M SBGR systems have been used for temporary installations on granular roadway surfaces to provide positive protection between traffic and the work area and workers. On several projects, Temporary Type M SBGR was specified for the first stage during a culvert replacement, and subsequently removed, salvaged, and reinstalled for a subsequent stage, and then finally, removed, salvaged and reinstalled as part of the permanent roadside barrier system on the project.

The system would be specified as a new SBGR installation along with required SBEATs or SBT for stage 1, and new items were created in MTO's Contract Preparation System for removal, salvage and reinstallation for stage 2. Additional information about Type M SBGR is provided in Section 4.2.2.

5.2 Temporary Crash Cushions

Approach ends of all temporary barrier system installations should be terminated by an appropriate terminal or crash cushion standard active in MTO's Contract Preparation System. Additional information about the need for barrier terminals and performance of crash cushions for permanent installations are similar to temporary installations are provided elsewhere in this manual.

The temporary crash cushions (energy attenuators) currently specified for temporary installations on provincial highway projects are listed in Table 5-1.

Energy Attenuator	NCHRP Report 350 or AASHTO MASH Test Level		Temporary Installation					
	TL-2	TL-3	Reduced Exposure (RE)	Narrow (NA)	Wide (WI)	Extra Wide (EW)	Super Wide (SW)	Dual Duty (DD)
TAU-M System	Yes	Yes	No	Yes	No	No	No	No
TAU-II Wide System	Yes	Yes	No	No	Yes	No	No	No
TAU-II Extra Wide System	Yes	Yes	No	No	No	Yes	No	No
ABSORB 350 System	Yes	Yes	Yes	No	No	No	No	No
ABSORB-M System	Yes	Yes	Yes	No	No	No	No	No
Quadguard M10 System	Yes	Yes	No	Yes	No	No	No	No
Quadguard Wide System	Yes	Yes	No	No	Yes	No	No	No
Quadguard Extra Wide System	Yes	Yes	No	No	No	Yes	No	No
Quadguard Super Wide System	No	Yes	No	No	No	No	Yes	No
ACZ 350 System	Yes	Yes	Yes	No	No	No	No	No
Sled System	Yes	Yes	Yes	No	No	No	No	No
Smart System	Yes	Yes	No	Yes	No	No	No	Yes

Table 5-1: Temporary Energy Attenuators

Additional information about Tau-II, Tau-M, QuadGuard, QuadGuard M10, and Smart systems for permanent installations are provided in Section 4.4.2 which is also applicable for temporary installations of these systems. When these systems are specified for temporary installations in work zones, designers need to verify that there will be at least 150 mm of asphalt pavement over compacted granular for any of these systems to be anchored according to manufacturers recommendations. If sufficient depth of existing asphalt pavement is not available at locations where temporary energy attenuators are being installed, it will be necessary to either specify hot mix paving to provide the minimum depth of asphalt for anchoring the system, or specify construction of a temporary concrete pad (or precast pad) to anchor the system. For temporary installations, the first TCB adjacent to the temporary energy attenuator also needs to be anchored to the pavement. See Figure 5-~~13~~20 and applicable standards active in MTO's Contract Preparation System showing a typical temporary energy attenuator and TCB layout.

For shorter term temporary energy attenuator installations where the system isn't scheduled to be in service during winter shutdown, where existing pavement thicknesses are less than 150 mm, and where minimum one metre offsets can be provided between the travelled lane and the attenuator, reduced exposure energy attenuators should be considered. Reduced exposure attenuators consist of plastic modules that are ballasted with water, and simply sit on the pavement surface without anchors. As these systems are gating, when installed adjacent to existing barrier systems, they either need to be installed with less than 0.3 m of clearance between the system and adjacent barrier, or be installed with more than 3 m clearance between the system and adjacent barrier. These systems also require a clear traversable area downstream of the system measuring at least 4 m wide by 22 m long, measured from the ~~front~~ upstream face of the system and parallel to the system. They also require at least 16 m of tangential TCB in line with the system beyond the connection. It is also recommended that reduced exposure systems are used where the chance of high speed, high angle impacts are low and penetration behind the barrier is acceptable. If these types of collisions may occur or penetration behind the barrier is not acceptable a narrow redirective crash cushion should be used. If the system does need to remain in-service when the temperature drops below freezing, anti-freezing agents will need to be added to the water in the modules to prevent them from freezing. Additional details for installation of reduced exposure systems on the end of temporary concrete barrier installations are shown in Figure 5-~~14~~21 and on the applicable standards active in MTO's Contract Preparation System.

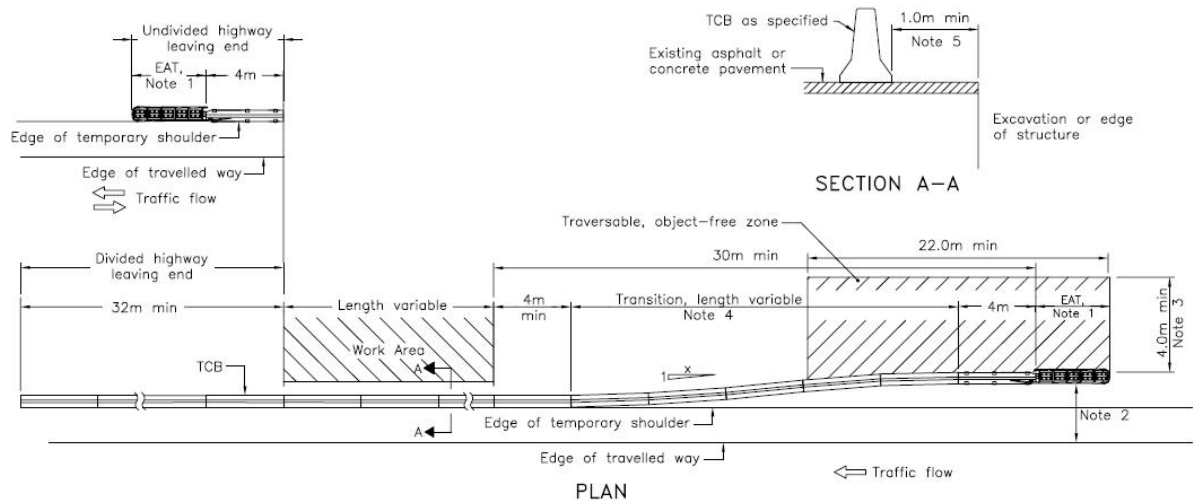

Figure 5-1320: Typical TCB Layout with Temporary Energy Attenuator.
See applicable standard for Notes

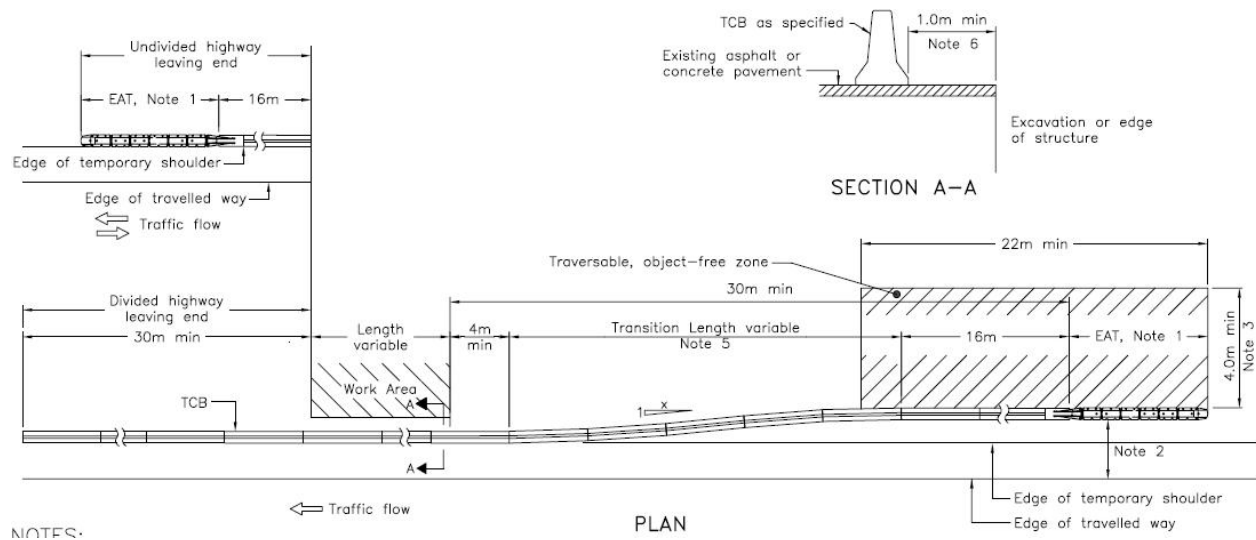

Figure 5-1421: Typical TCB Layout with Temporary Reduced Exposure Energy Attenuator.
See applicable standard for Notes

5.2.1 Reduced Exposure Energy Attenuators

5.2.1.1 Absorb 350 Reduced Exposure Temporary Energy Attenuator System

The Absorb 350 System is a proprietary non-redirective, gating, crash cushion that meets the crash test acceptance requirements of NCHRP Report 350 TL-2 and TL-3.



Figure 5-~~1522~~: Absorb 350 Temporary Reduced Exposure Energy Attenuator

The system consists of a nosepiece assembly followed by a series of four, eight, or nine low density polyethylene element assemblies, and a transition assembly.

There are two types of element assemblies (Type A and Type B) that are alternated when installed. Both types of elements are 1000 mm long by 800 mm tall by 610 mm wide. The first element in is not filled with water. The elements are connected together using steel pins.

The system is not anchored, but does require a paved surface.

The Absorb 350 system is also used with the Quickchange Moveable Barrier System. The ABSORB 350 System can pass through the Barrier Transition Machine during barrier shifts.

Manufacturer: Lindsay Corporation - Barrier Systems

Web Site: <http://www.barriersystemsinc.com/>

5.2.1.2 ABSORB-M Reduced Exposure Temporary Energy Attenuator System

The ABSORB-M System is a proprietary non-redirective, gating, crash cushion that meets the crash test acceptance requirements of MASH TL-2 and TL-3.



Figure 5-~~1623~~: ABSORB-M Temporary Reduced Exposure Energy Attenuating System

The system consists of a nosepiece assembly followed by a series of two (TL-2) or three (TL-3) low density polyethylene element assemblies, and a transition assembly.

The TL-2 system is 0.45m long by 1070mm tall by 610mm wide while the TL-3 system is 0.64m long with the same width and height dimensions. The elements are connected using exterior steel rods.

The system is not anchored but does require a paved surface.

Unlike the ABSORB-350 system, The ABSORM-M cannot be used in conjunction with the Quickchange Moveable Barrier System.

Manufacturer: Lindsay Corporation - Barrier Systems

Web Site: <http://www.barriersystemsinc.com/>

5.2.1.3 ACZ 350 Reduced Exposure Temporary Energy Attenuator System

The ACZ 350 System is a proprietary non-redirective, gating, crash cushion that meets the crash test acceptance requirements of NCHRP Report 350 TL-2 and TL-3.



Figure 5-~~1724~~: ACZ 350 Temporary Reduced Exposure Energy Attenuator

5.2.1.4 SLED Reduced Exposure Temporary Energy Attenuator System

The SLED System is a proprietary non-redirective, gating, crash cushion that meets the crash test acceptance requirements of NCHRP Report 350 TL-2 and TL-3.



Figure 5-~~1825~~: SLED Temporary Reduced Exposure Energy Attenuator

The system consists of a nosepiece assembly followed by a series of four, eight, or nine low density polyethylene element assemblies, and a transition assembly.

There are two types of element assemblies (Type A and Type B) that are alternated when installed. Both types of elements are 1000 mm long by 800 mm tall by 610 mm wide. The first element in is not filled with water. The elements are connected together using steel pins.

The system is not anchored, but does require a paved surface.

Manufacturer: TraFix Devices Inc.

Web Site: <https://www.traffixdevices.com/>

5.3 Transitions to Temporary Concrete Barrier

Within work zones, it may be necessary to provide a positive connection between an existing permanent concrete barrier system and temporary concrete barrier installation within a work zone, or between an existing SBGR installation and a temporary concrete barrier installation within a work zone. Providing a positive connection instead of specifying a temporary energy attenuator would likely be recommended for long term work operations, including during winter shutdown periods. New crash tested standards that were implemented in 2018 for use on provincial highway projects are summarized below.

Transition from Permanent SBGR to Temporary Concrete Barrier:

The layout shown in Figure 5-~~19~~26 was developed and crash tested by Midwest Roadside Safety Facility (MwRSF) according to MASH TL-3. The Type M SBGR transition between the existing SBGR installation and the TCB will need the steel posts to be installed into the granular base or gravel shoulder. The posts should not be installed through pavement. The first three units of TCB may be installed on gravel in vicinity of the connection.

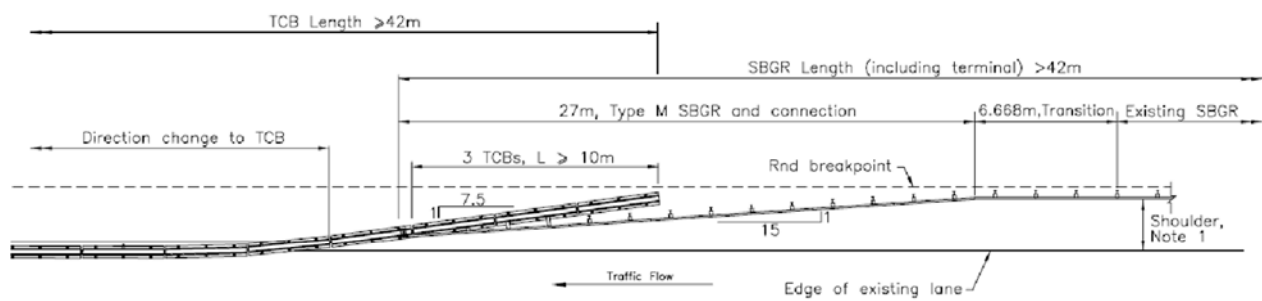

Figure 5-~~19~~26: Transition from Existing SBGR to TCB
Photo courtesy of MwRSF

Transition from Permanent Concrete Barrier to Temporary Concrete Barrier:

The Concrete Barrier Temporary Transition is a proprietary redirective system that meets the crash test acceptance requirements of MASH TL-3. The system connects and transitions from permanent concrete barrier to temporary concrete barrier eliminating the need for a crash cushion. The transition includes a Steel Transition Plate that is 10.9 m long by 802 mm high and 6.35 mm thick. The Steel Transition Plate is angled at 3.1 degrees between the existing permanent concrete barrier and three pinned 4 m long modified Type X TCB units. The barrier following the three pinned Type X temporary concrete barrier can either continue as Type X or be transitioned to another type of temporary concrete barrier.

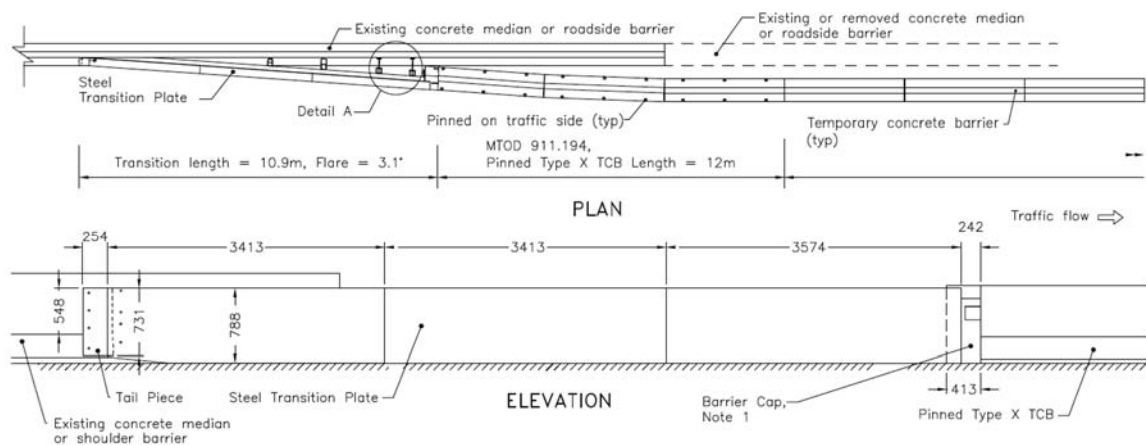

Figure 5-2027: Transition from Permanent Concrete Barrier to Temporary Concrete Barrier
Photo courtesy of Powell Construction and TTI.

Manufacturer: Northern Infrastructure Products Inc.

Web Site: <http://www.northern-ip.com>

May-2020TBD, 2023

5.4 Temporary Work Zone Signs

5.4.1 Skid-Mounted Temporary Sign Supports

The skid-mounted sign support system is a non-proprietary breakaway sign support design that meets the crash test acceptance requirements of MASH TL-3. It was tested for the Texas Department of Transportation by the Texas Transportation Institution in 2014.

The system consists of a sign board, fastened to either a two or three post support system using wooden posts (although a 5-post support system was crash tested as shown in Figure 5-28). The supports are fastened to a wooden skid base which is placed on the surface of the roadside in a construction zone. The wooden skid base is weighed down using 18 kg sandbags. Two 51 mm holes are drilled at the bottom of the posts to facilitate predictable fracturing.

Sign support dimensions, post spacing and number of sandbags are dependent on the sign board area. For two-post sign support system, sign sizes ranging from 90-180 cm wide x 105-180 cm high to a maximum sign area of 3.24 m² can be used. For three-post sign support system, sign sizes ranging from 210-240 cm wide x 180-210 cm high to a maximum sign area of 5.04 m² may be installed.

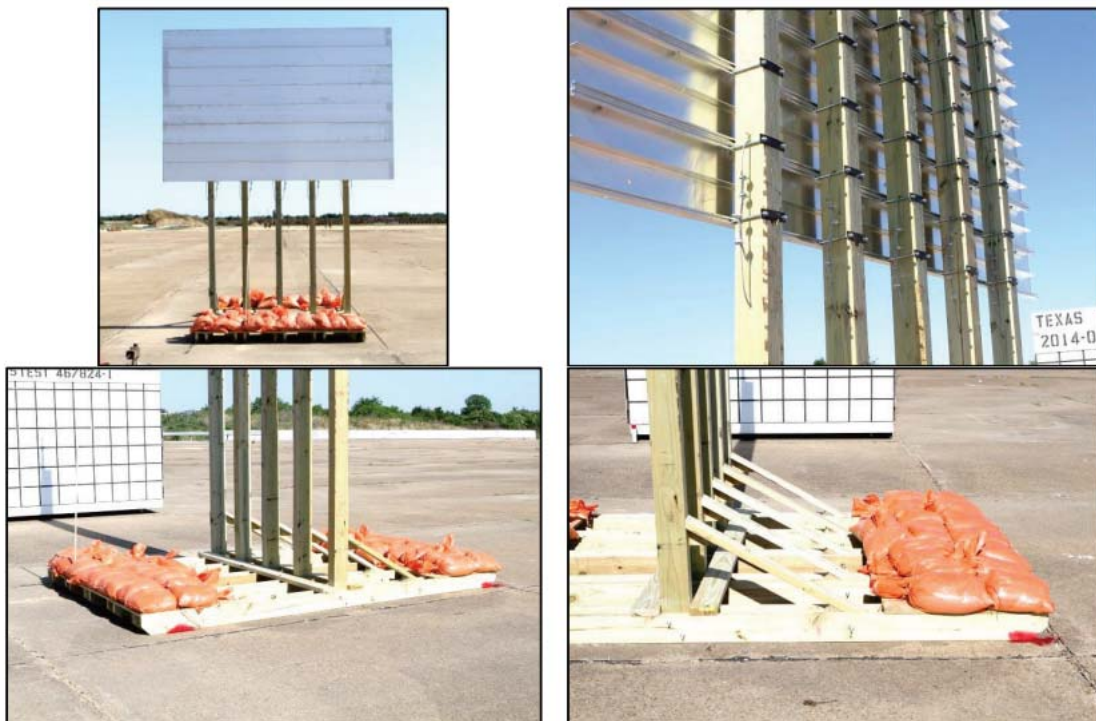

Figure 5-28, Skid-Mounted Temporary Sign Support

In head on impacts, the wooden sign supports fracture at bumper height and below the sign board. The skid base also is displaced slightly in the direction of travel of the impacting vehicle.

This sign support should only be used on terrain with a maximum transverse slope of 10H:1V and should not be used in locations with a potential of impacts other than by a vehicle approaching the broad side of the sign support.