

4. Roadside Safety Hardware

As stated in Section 1.0, designers should achieve a balance between competing objectives and constraints when determining how the roadside environment will be configured. The choices made to achieve this balance will be influenced by the:

- Functional classification;
- Design speed;
- Operating speed;
- Posted speed;
- Traffic volumes and composition;
- Drainage considerations;
- Pavement design considerations;
- Right-of-way (ROW) constraints (such as property limits, environmental)
- Other ROW user expectations (such as utility companies);
- Access requirements (such as entrances);
- Constructability considerations;
- Maintenance considerations;
- Funding considerations; and
- Other constraints (such as social, political, technological).

When it has been determined that installation of new roadside safety hardware is justified and cost beneficial for inclusion in a provincial highway project, the hardware specified should meet the safety requirements and criteria specified in this manual and have been implemented in MTO's Contract Preparation System or issued specifically for a project by the appropriate functional office within Highway Standards Branch.

New roadside safety hardware installations, including barriers, terminals, transitions, crash cushions, breakaway sign supports, and frangible base luminaire poles, should meet applicable crash test level acceptance criteria referenced in Section 2.4 and as referenced in each of the following sections for each system. This applies to both permanent systems and temporary systems used in work zones.

The barrier and terminal systems listed in this chapter are complete as of the time of issue of this manual. New systems are often accepted for use on provincial highways between publications of the manual and designers are encouraged to keep informed of the most current

version of all standards specifications, special provisions, standard drawings and policy memoranda pertaining to roadside hardware.

Systems shall not be modified from the configurations shown in the standards. Highway Design Office shall be contacted for guidance in case site-specific constraints preclude the use of roadside hardware in its standard configuration.

Existing roadside safety hardware installations on provincial highways providing acceptable in service safety performance and system condition should continue to perform as originally intended until the end of their service life.

4.1 Barrier Systems

Although barrier systems are designed and crash tested to reduce the severity of injuries to occupants in errant passenger vehicles during collisions with roadside obstacles within the roadside environment, dependent on the type of impact, significant vehicle damage can occur along with injury to occupants. Once a barrier system comes into use, the crash is already in progress. The primary purpose of a barrier system is therefore not to prevent a crash, but rather to minimize the severity of the crash.

The severity of the collision with the barrier system should be less than the severity of an impact with a roadside obstacle (e.g. a fixed object or terrain feature) had the barrier not been in place. A barrier system is a device which provides a physical limitation through which an errant vehicle would not normally pass. Barrier systems are designed and crash tested to contain or redirect an errant design vehicle of a particular size range, at a given speed and angle of impact.

Barrier systems are categorized into two major categories based on configuration, function, and location:

- Roadside Barrier – a single sided longitudinal barrier system intended to redirect errant design vehicles from departing the roadway and encroaching into the roadside environment.
- Median Barrier– a double sided longitudinal barrier system used to redirect errant vehicles from crossing a median.

Roadside barrier systems are designed and crash tested to redirect errant vehicles that impact one side of the barrier system from either direction (e.g. bidirectional). They are typically used to shield motorists from natural and man-made obstacles located along either side of the travelled way of highways or ramps. This includes the left side of divided highways with wide

medians. Under certain conditions on certain facilities, barriers may also be used to separate high speed vehicular traffic from other facilities such as pedestrian sidewalks, active transportation paths, and snowmobile trails.

A median barrier system is designed and crash tested to redirect errant vehicles that impact either side of the barrier system from either direction within a median. Medians are typically used to separate the travelled ways for traffic in opposing directions, or to separate the travelled ways to manage access (e.g. core-collector systems or service roads).

Temporary barrier systems are designed and crash tested for use in construction work zones to provide physical separation between motorists and certain long term work zone operations. They are typically precast temporary concrete barrier systems or temporary steel barrier systems that are installed on paved surfaces that can be picked up and moved during construction for different construction stages, or steel beam guide rail systems installed temporarily through granular surfaces during construction that can be removed, salvaged, and reinstalled for different construction stages.

4.1.1 Barrier System Types

Barrier systems are further categorized into three system types based on dynamic deflection characteristics and working width requirements:

- Flexible;
- Semi-rigid; and
- Rigid.

Dynamic deflection is the maximum distance that the barrier system is expected to deflect laterally under a specified design impact, measured from the ~~front~~traffic face of the system. Working width is the distance between the traffic face of the system before impact in accordance with a specified crash test and the maximum lateral position of any major part of the system or vehicle after the crash test.

Flexible barrier systems are generally more forgiving than semi-rigid and rigid barrier systems since much of the impact energy is dissipated during deflection of the barrier system. Greater dynamic deflections of flexible barrier systems tend to result in lower impact forces being imposed on the impacting vehicle than with impacts with semi-rigid and rigid barrier systems. In general, flexible barrier systems consist of three or four steel cables mounted on weak steel posts.

Semi-rigid barrier systems are more rigid than flexible barrier systems and more forgiving than rigid barrier systems. In general, these systems consist of steel beams or rails mounted on strong steel posts.

Rigid barrier systems have minimal working widths and either don't deflect or have minimal deflection. In general, these systems are constructed from concrete and are embedded into the pavement surface.

Semi-rigid and flexible barrier systems should only be used if there is a sufficient working width provided between the traffic face of the system and the obstacle beyond the back of the system to accommodate dynamic deflection under the specified design impact. If the barrier system is placed too close to the obstacle, the impacting vehicle can deflect the barrier system into the obstacle, allowing the vehicle to interact with the obstacle.

4.1.2 Barrier System Performance

The performance of barrier systems is dependent on the design, installation, maintenance, and post-impact repair. Associated grading and appropriate terminals, leaving ends, or anchorage requirements, should be provided for each specific barrier system in order for the barrier system to perform as designed and crash tested.

In order to be effective, a barrier system should be capable of restraining a selected design vehicle under specified impact conditions (design vehicle of a particular size range, at a given speed and angle of impact). A barrier system should prevent the selected design vehicle from the following:

- penetrating,
- vaulting over (over-riding), or
- wedging under (under-riding) the installation.

Unless otherwise designed, the barrier system should remain substantially intact so that system elements and debris will not pose an undue risk to occupants in the impacting vehicle or other traffic. The barrier system should be designed and installed to reduce the risk of spearing an impacting vehicle. A vehicle-barrier system collision should result in redirection of the impacting vehicle at a low departure angle that will minimize the risk of interacting with other vehicles. Finally, the collision should not result in excessive lateral or longitudinal deceleration of the vehicle's occupants.

Barrier systems, whether they are rigid, semi-rigid or flexible, should be of sufficient length and be properly terminated and anchored. In the case of rigid systems, sufficient length,

embedment and mass are necessary to prevent the system from being displaced significantly upon impact.

Since the dynamics of a collision are complex, the most effective means of assessing barrier system performance is through full-scale crash testing. By standardizing such tests, barrier system designers can compare the relative safety performance of alternative systems. As noted in the following subsections, MTO has started to implement installations of new roadside safety hardware on provincial highways that meets the crash test and evaluation criteria contained in the AASHTO Manual for Assessing Safety Hardware (MASH (2009 or 2016)). Where roadside safety hardware that meets MASH is currently not available or been implemented by MTO, new roadside hardware installations should continue to meet National Cooperative Highway Research Program Report 350 - Recommended Procedures for the Safety Performance Evaluation of Highway Features (NCHRP Report 350 (1993)).

It is important to highlight that the performance and mechanisms of vehicle containment of barrier systems is not always intuitive. Crash-test and in-service behaviour of barriers and crash cushions can be unpredictable and surprise even those with decades of experience designing, simulating and testing barriers. Nuances and variations in seemingly insignificant components such as offset block height, or the presence or absence of a washer can result in major changes in barrier performance and can mean the difference between successful containment of a vehicle and a catastrophic failure. For this reason, it is imperative that systems be installed in exactly the configuration prescribed in this manual and all applicable standard specifications and drawings and any proposed changes, no matter how minor, be made only in consultation with the Highway Design Office.

4.2 Roadside Barrier Systems

A roadside barrier system is a single sided longitudinal barrier system intended to redirect errant design vehicles from departing the roadway and encroaching into the roadside environment.

The following roadside barrier systems have been implemented for installation as new roadside barrier systems on Provincial Highways:

Flexible Roadside Barrier Systems:

- High Tension Three-Cable Guide Rail (HT3CGR)

Semi-Rigid Roadside Barrier Systems:

- Type M Steel Beam Guide Rail (Type M SBGR)
- Australian Construction Products Sentry Guide Rail
- Ingal Civil Products Ezy-Guard 4 Guide Rail
- Guardian 5 Steel Beam Roadside Barrier

Rigid Roadside Barrier Systems:

- Concrete Roadside Barrier (CRB)

Description and design guidance for each barrier system are described in the applicable sections.

4.2.1 High Tension Three Cable Guide Rail

All MTO contracts advertised after December 31, 2016 that included new or replacement installations of cable guide rail should have specified High Tension Three Cable Guide Rail (HT3CGR) and High Tension Cable Guide Rail Terminal Systems in the contract documents. On MTO contracts advertised prior to December 31, 2016, cable guide rail installations consisted of low tension three cable guide rail systems mounted to wooden posts.

Description:

High Tension Cable Guide Rail (HTCGR) systems are proprietary flexible barrier systems with wire ropes that are pre-tensioned to significantly higher tension values than cables for low tension systems used throughout Ontario since the 1960s. The HTCGR cables are 19 mm diameter, 3 by 7 construction steel wire rope according to AASHTO M 30 with a minimum breaking strength of 173.5 kN, and Type I Class A zinc coating, whereas the low tension system used 12 mm diameter, 7-wire strand steel wire rope according to CAN/CSA G12, grade 800 with a minimum breaking strength of 74 kN and a maximum breaking strength of 100 kN, hot zinc-coated or class A electro-zinc-coated.

At this time, one proprietary system, the Safence HT3CGR system manufactured by Gregory Industries Inc., is currently specified by MTO for shoulder installations and slope installations. This system meets the crash test evaluation acceptance requirements of AASHTO MASH TL-3.



Figure 4-1: Safence HT3CGR Installation

Advantages and Disadvantages:

Advantages of HTCGR installations when compared to semi-rigid and rigid barrier systems are:

- Less visual obstruction;
- Suited for open areas where blowing snow may cause drifting;
- Slope installations can provide increased offset from travelled way on narrow embankments to provide additional clearance for snow plows, oversize loads, and likely fewer vehicular impacts;
- System will continue to function after impacts where several posts have been damaged as tension in system should keep cables at proper mounting heights; and
- More forgiving due to lower deceleration forces sustained by vehicle and occupants during impact.

Disadvantages of HTCGR installations when compared to semi-rigid and rigid barrier systems are:

- Higher dynamic deflection and working width requires larger clear area behind the system;
- Cable tension needs to be monitored;
- No transitions currently available for interconnection with other systems;
- More susceptible to damage from snow plows and minor collisions;
- Impacts into terminal may result in entire system becoming non-functional until repaired' and
- More expensive than low tension cable systems historically used in Ontario

Design Guidance:

HTCGR should be considered when steel beam guiderail cannot provide a minimum offset of 4.25m from the roadway centerline to the face of SBGR on narrow roadways. HTCGR installations should be offset a minimum of 4.25 m from the roadway centerline to provide clearance for snowplowing operations.

HTCGR systems may be installed on the inside and outside of horizontal curves with centerline radii of 250 m or greater.

The recommended minimum length of a HTCGR system is 100 m including terminals, and the maximum recommended installation length is 6,000 m including terminals.

The Safence High Tension Three Cable Guide Rail (HT3CGR) system may be installed at the edge of shoulder as a shoulder installation, or just beyond the shoulder breakpoint as a slope installation. Shoulder installations have the line posts installed at the edge of shoulder in front of the rounding breakpoint, where the breakpoint in rounding is typically 250 mm from the

edge of shoulder as part of the 0.5 m wide rounding. Slope installations have the line posts installed up to 200 mm beyond the shoulder breakpoint on foreslopes as steep as 2H:1V. For new construction, new granular base side slopes should be 3H:1V or flatter as specified.

The Safence HT3CGR system uses three 19 mm diameter pre-stretched cables mounted on proprietary direct driven rectangular galvanized steel line posts spaced at 2 m intervals. Each cable is tightened to the manufacturer's specified tension typically ranging from 20 kN to 40 kN dependant upon the temperature of the cable. At 20° C, cable tension should be 13.7 kN. At -20° C, cable tension should be 25.5kN.

Turnbuckles are used to achieve the specified tension in the cables according to Contract Documents and manufacturer's instructions. Turnbuckles should be installed at 305 m intervals, and may be located above one another (eg. between same posts).

The reported working width for Safence HT3CGR system is 2.2 m based on MASH-09 TL-3 crash test 3-11 for a slope installation on a 2H:1V slope with a installation length of 172.4 m including terminals. The reported maximum dynamic deflection from crash test 3-11 was 2.0 m.

Modified Safence HT3CGR line posts may be installed over shallow culverts or other buried obstacles with depths of cover ranging from approximately 1.4 m to 0.8 m. This will require the standard 2256 m long line posts to be shortened by up to 0.3 m or up to 0.5 m to reduce embedment depths while reducing line post spacing from standard 2 m spacing to 1.5 m or 1.0 m spacing accordingly.

Length of need for the HT3CGR system starts at post 6 of the terminal system, or 12 m from the terminal anchor assembly.

HTCGR installations should not be installed in front of or behind curbs.

Retroreflective sheeting measuring 125 mm high for line posts should be wrapped around the approach, traffic, and leaving side of line posts between the top and middle cable at maximum intervals of 20 m on tangents. On horizontal curves, spacing of retroreflective sheeting on line posts should be reduced according to requirements in OTM Book 11.

Approach and leaving ends of Safence HT3CGR system installations should be anchored with Safence end terminals as described below.



Figure 4-2: Safence HTCGRT installation

End Treatments and Terminals:

The 12 m long Safence terminals for shoulder installations are flared away from the edge of shoulder over a length of 20 m (including 5 line posts) to provide an offset of 0.6 m from the edge of shoulder to the centre of the terminal anchor assembly to minimize potential for damage from snowplows and impacts by errant vehicles. In vicinity of the terminal, the roadway is widened beyond the edge of shoulder by at least 1.2 m to accommodate the flaring of the terminal and provide a relatively flat area for impacts by errant vehicles.

The 12 m long Safence terminals for slope installations are not flared away from the edge of shoulder. When line posts and terminal posts are installed 0.2 m beyond the shoulder rounding breakpoint, and assuming the width of rounding in front of the breakpoint is 0.25 m, the offset from edge of shoulder to centre of the terminal anchor assembly is 0.45 m to minimize potential for damage from snowplows and impacts by errant vehicles. In vicinity of the

terminal, the roadway is widened beyond the centre of the anchor assembly by 0.6 m or at least 1.05 m to provide a relatively flat area for impacts by errant vehicles.

The area immediately downstream of the terminal anchor assembly for shoulder installations and slope installations measuring 23 m x 6 m should be clear and traversable.

Terminals should be delineated with an Object Marker and Snow Plow Marker placed at the edge of shoulder 2 m in advance of an approach end terminal or 2 m beyond a leaving end terminal to minimize potential for damage from snowplows and impacts by errant vehicles. When terminals are impacted by snowplows or errant vehicles, the terminal system is designed to release the cables during impacts, making the entire length of the HT3CGR installation non-functioning until repaired.

Each cable end of the HT3CGR installation is tethered with check cables to the terminal anchor assembly. The purpose of the check cables is to keep released cable ends in proximity to the terminal anchor assembly when released during an impact with the terminal.

Transitions:

There are currently no acceptable transitions available for transitioning and connecting HT3CGR to semi-rigid barriers or rigid barrier systems.

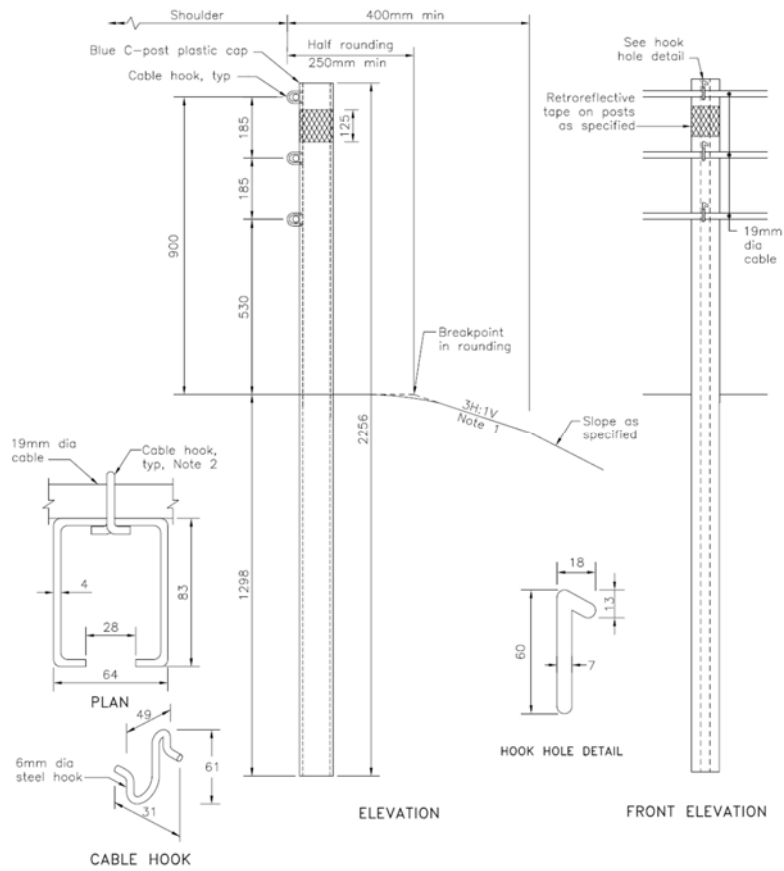

Figure 4-3: Safence HT3CGR Shoulder Installation

See applicable standard for Notes.

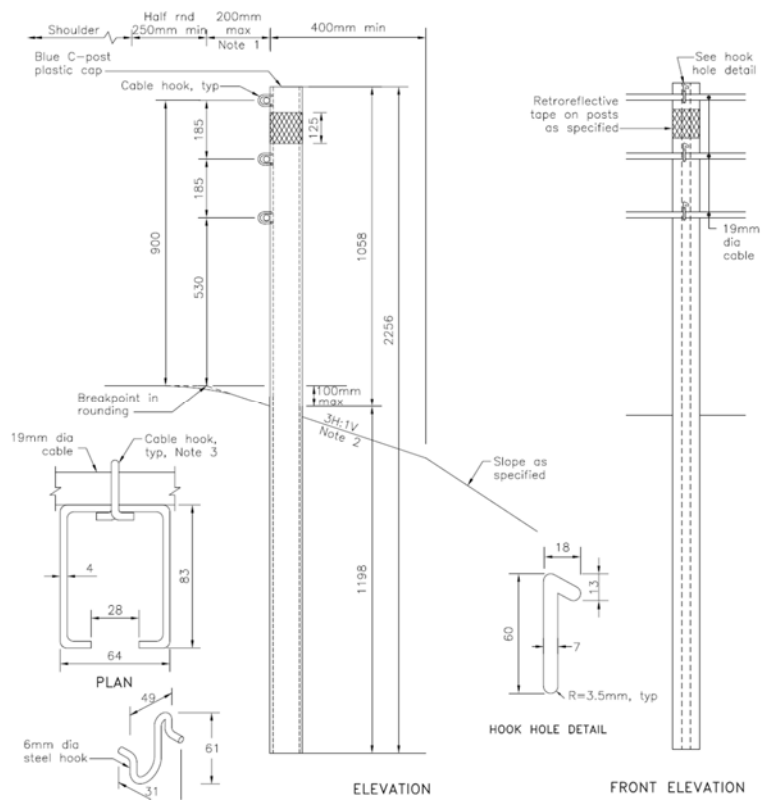

Figure 4-4: Safence HT3CGR Slope Installation
See applicable standard for Notes

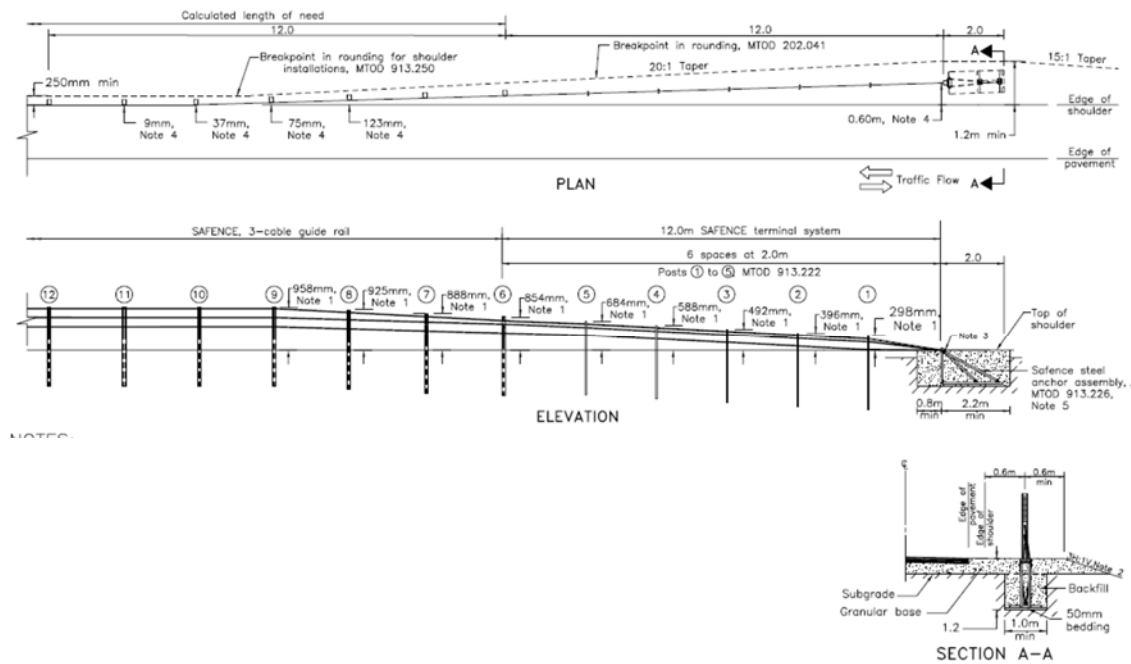

Figure 4-5: Safence HTCGRT Shoulder Installation
See applicable standard for Notes

4.2.2 Steel Beam Guide Rail

All MTO contracts advertised after May 27, 2016 that included new installations of Single Rail Steel Beam Guide Rail should have specified Steel Beam Guide Rail in the contract documents. New installations of Single Rail Steel Beam Guide Rail with Channel should be specified at structure connections only.

4.2.2.1 Midwest Guardrail System

Description

Type M SBGR, which is called Midwest Guardrail System (MGS) in the United States, is a non-proprietary single rail SBGR system that was originally developed and crash tested by the Midwest Roadside Safety Facility (MwRSF) at the University of Nebraska through the Midwest States' Regional Pooled Fund Program. The system was developed to improve performance and capacity of the standard SBGR systems previously installed throughout North America over the past sixty years. The revisions to the standard SBGR system included a modification to the standard W-beam rail to shift the rail splices away from the posts so that they are now located mid-span between posts as detailed in Figure 4-6. The top of rail was increased from a nominal height of 685 mm to 785 mm. The system continues to use standard 1829mm long W150x13 steel posts spaced at 1.905 m and standard 20 cm deep routed wooden or plastic offset blocks (Type M20 SBGR) or 30 cm deep routed wooden or plastic offset blocks (Type M30 SBGR). Type M SBGR when installed into cross-section of various configurations described below meets the crash test acceptance requirements of MASH TL-3.

All standard SBGR and Type M SBGR systems use a W-beam rail with a height of 311 mm and a nominal thickness of 2.67 mm (12 gauge). The W-beam rails have a nominal length of 3.81 m (total rail length of 4.128 m including laps for splices) and are overlapped and spliced together using eight splice bolts at each end, and mounted to the offset blocks and posts using appropriate post bolts specific to the type of offset block and post.

The plastic offset blocks offer several installation advantages over wooden offset blocks and are generally preferred by guide rail installers. Plastic blocks are generally lighter than wooden offset blocks and they have a self-hanging finger that allows the block to be hung on the post rather than held in position while the rail is being mounted. Plastic offset blocks include recycled plastics, and they can also be further recycled into plastic products at the end of their service life. Existing pressure treated wooden offset blocks are prone to splitting and cracking as they age, and when removed at the end of their service life are typically disposed of at landfill sites. Currently, three plastic offset blocks are accepted and specified by MTO for new SBGR installations:

- King Block, manufactured by Trinity Highway Products, LLC;
- Mondo Block, manufactured by Mondo Polymer Technologies; and
- P-Block, manufactured by R. G. Steel Corp.

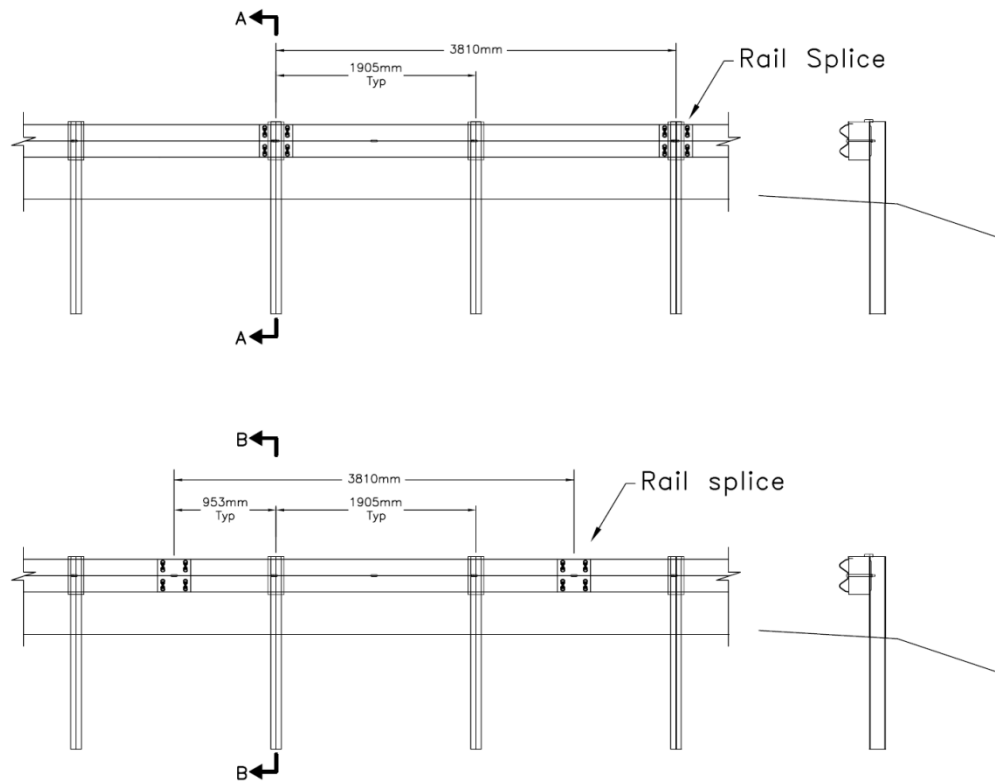

Figure 4-6: Rail Splice Locations on Standard SBGR vs Type M SBGR

- **Advantages and Disadvantages:**

The main advantages of Steel Beam Guide Rail are:

- Lower maintenance requirements compared to flexible systems;
- Lower dynamic deflection than flexible systems;
- Lower construction cost than rigid systems;
- Can be transitioned and connected directly to structures;
- May be installed at shoulder breakpoints with foreslopes as steep as 2H:1V when installed with longer steel posts; and
- May continue to function after minor impacts prior to repair.

The main disadvantages of Steel Beam Guide Rail are:

- Higher maintenance requirements compared to rigid systems;
- Higher dynamic deflection than rigid systems; and
- Higher construction cost than flexible systems.

Design Guidance:

Installations must be offset a minimum of 4.25 m from the roadway centerline, to provide clearance for snowplowing operations.

SBGR systems may be installed on the inside and outside of horizontal curves with centerline radii of 45 m or greater. Sharper radius curves require rails to be shop bent at the manufacturer's plant prior to hot dip galvanizing.

The minimum installation length is 25 m including terminals and leaving end treatments, and there is no maximum installation length.

Standard post spacing is 1.905 m, which may be decreased to 0.952 m or 0.476 m to reduce dynamic deflection during impacts. See Table 4.1.

Standard rail mounting height for Type M SBGR measured at face of barrier to top of rail is 785 mm +/- 25 mm. Type M SBGR can accommodate future pavement overlays up to 50 mm in thickness as long as the top of rail is maintained at a minimum height of 710 mm.

Type M20 SBGR should be installed at the edge of shoulder with 1.0 m rounding, where the breakpoint in rounding to a 3H:1V or flatter granular sideslope is a minimum of 500 mm from the edge of shoulder. For additional details see Figure 4-7.

Type M30 SBGR may be installed beyond the edge of shoulder when the surface is 10H:1V or flatter, and may be installed with a flare rate up to 10:1.

Type M30 SBGR may be installed a maximum of 125mm behind barrier curb for TL-3 installations, and a minimum of 1.8 m behind barrier curb with boulevard or sidewalk for TL-2 installations. See Figure 4-7.

Type M20 SBGR with longer 2.438 m long W150x13 steel posts may be installed adjacent to shoulders with the traffic face of post set at the breakpoint in rounding to a 2H:1V or flatter granular sideslope. Erosion of the 2H:1V granular sideslope is a concern which may result in increased maintenance costs and reduced performance of the barrier. This configuration should be used when alternatives are limited. At top of the 2.438 m long post, the number "8" is stamped to signify that the post is 8 feet (2.438 m) long, and when damaged, should be replaced with a 2.438 m long post.

Type M SBGR posts may be installed into solid rock by drilling or breaking out a hole in the rock to allow rotation of the steel posts during impacts. For solid rock within 460 mm of the surface, the diameter of the hole needs to be 530 mm or greater for steel posts. The diameter of the

hole below a depth of 460 mm needs to be 254 mm or greater, and advanced to a depth at least 50 mm below bottom of specified post. The front of the hole should align with the traffic face of the post, and be backfilled with compacted granular base material.

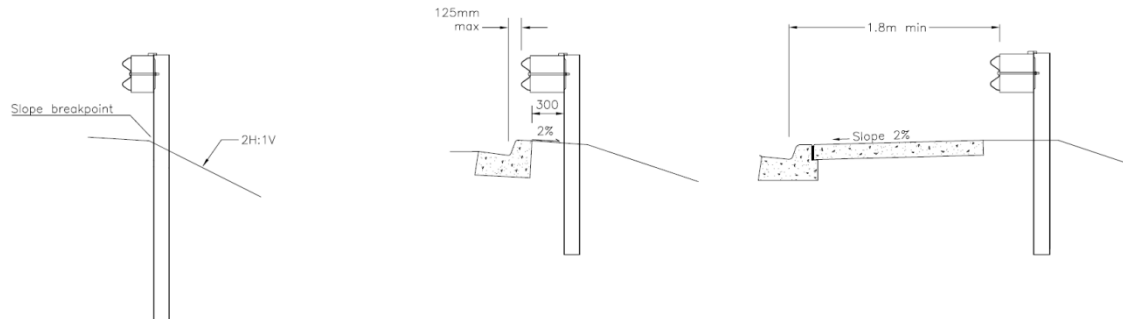

Figure 4-7: Various Type M SBGR Installation Configurations

Type M SBGR systems may be installed through asphalt or concrete by providing leave-outs in the surface to rotation of the steel posts during impacts. Steel posts need to be centred in leave-outs at least 381 mm long (parallel to roadway) and traffic face of posts need to be placed 50 mm beyond front edge of leave-out at least 381 mm wide (perpendicular to roadway) to provide at least 177 mm of clearance from back of post to edge of leave-out. The leave-out should extend the full depth of asphalt pavement or concrete, and be backfilled with compacted granular base and granular sealed.

Long span Type M SBGR may be installed over shallow culverts or buried obstacles with depths of cover less than 1.2 m and lengths (parallel to roadway) up to approximately 7 m. The modification uses three 145 mm x 195 mm drilled breakaway wooden posts with double 145 mm x 195 mm wooden offset blocks installed on either side of a span without posts 7.62 m long. There is also a version with a span without posts 5.715 m long. The embankment over the length of the treatment shall be widened to provide a minimum platform width of 600 mm behind the posts with a slope of 10H:1V or flatter. No obstacles, headwalls or exposed edges of culvert shall be present within 1.6 m of the traffic face of this treatment to allow for deflection during impacts. On both sides of the 7.62 m span without posts, there needs to be at least 19.05 m of SBGR on the approach side and on the leaving side including terminals. For additional details see Figure 4-8.

Base plated Type M SBGR may be epoxy bolted to the top of shallow concrete box culverts with lengths greater than 7 m (parallel to roadway) with depths of cover ranging from 1.0 m to 0.207 m. When bolting to the top of precast concrete box culverts, a concrete slab at least 200 mm

thick and at least 1.2 m wide (measured perpendicular to roadway) should be specified to accommodate the four epoxy anchors. The 23 mm thick steel base plate is welded to the W150x14 steel post by the manufacturer prior to hot dip galvanizing, and the steel post is cut to length to provide the specified w-beam mounting height.

Transition from Type M SBGR to existing standard SBGR or existing Steel Beam Energy Attenuators (SBEAT) or Eccentric Loader Terminals (ELT) should take place over a minimum length of 6.6 m.

The cable assembly attaching post 1 of a SBEAT, SBT, ELT, or leaving end treatment to the SBGR rail needs to be kept snug to allow tensile forces that develop in the rail during impacts to be transferred to the foundation tube below post 1.

When steel posts are potentially in conflict with a shallow buried utility or drainage pipe, it is acceptable to omit one post in vicinity of conflict. The minimum distance between omitted posts in a SBGR installation is 17.1 m. No modification to the rail is required at the location of an omitted post.

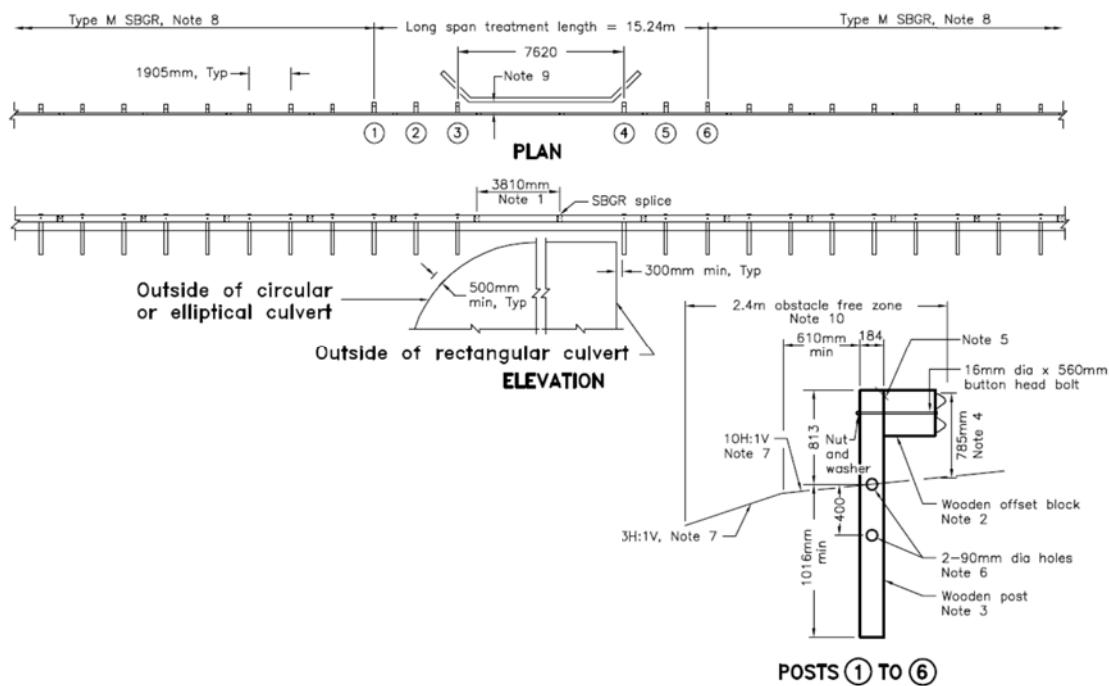

Figure 4-8: Long Span Treatment for Low Fill Culverts

See applicable standard for Notes

Working widths for various configurations and test levels are provided in Table 4-1.

Installation Configuration	Post Spacing (m)	Post Length (m)	Working Width MASH-09 (m)	
			TL-3	TL-2
Type M20	1.905	1.829	1.4	1.2
Type M20 adjacent to 2H:1V slope	1.905	2.438	1.4	Note 1
Type M30 adjacent to barrier curb	1.905	1.829	1.3 Note 2	1.0
Type M30 Offset 1.8 m from face of barrier curb	1.905	1.829	Note 3	1.2
Type M20 with ½ post spacing	0.953	1.829	1.02	Note 1
Type M20 with ¼ post spacing	0.476	1.829	0.9	Note 1
Type M Long Span	7.62	1.829	2.4	Note 1
Type M20 base plated	1.905	Variable	1.3	Note 1

Table 4-1: Working Widths for Type M SBGR Installations

Note 1: Working widths values for this configuration and test level currently not available.

Note 2: Working width based on NCHRP Report 350 crash test 3-11.

Note 3: Configuration not recommended for high speed roadways with posted speeds of 70 km/h and greater. Configuration meets the crash test acceptance requirements of NCHRP Report 350 TL-2.

Reflectors with a minimum reflective surface of 100 x 100 mm and flexibility to bend 90 degrees from vertical and self-restore are attached to the top of the Type M steel posts at maximum intervals of 20 m on tangents. On horizontal curves, spacing of reflectors should be reduced according to requirements in OTM Book 11.

Approach and leaving ends of the system installations should be anchored with crashworthy end terminals, leaving end treatments, or transitioned from / to rigid barrier system.

End Treatments and Terminals:

In order to allow development of tensile strength in the SBGR system within the length of need, both ends of the SBGR system installation need to be anchored.

Each end of the SBGR system installation should be anchored by an appropriate end treatment, terminal system, or structure / concrete barrier connection.

A crash worthy terminal system should be installed at the following locations:

- Approach end on divided highways and one-way ramps;
- Approach and leaving end on undivided highways and two-way ramps; and
- Left (median) shoulder on the leaving end on divided highways (eg. divided by a depressed median, median barrier, or median island, and excludes flush medians) when the leaving end is located within the clear zone for opposing traffic.

Crash worthy Type M Steel Beam Energy Attenuator Terminals (SBEAT) currently specified for installations on provincial highway projects are as follows:

- MASH Sequential Kinking Terminal System (MSKT);
- MASH SoftStop Terminal System; ~~and~~
- ~~MASH Max-Tension Terminal System; and-~~
- MASH SPIG Gating End Terminal (SGET)

Crash worthy Type M Steel Beam Terminals (SBT) currently specified for installations of Type M SBGR on horizontal curves with centreline radii less than 190 m on provincial highway projects are as follows:

- MASH Slotted Rail Terminal (SRT)
- MASH Flared Energy Attenuating Terminal (MFLEAT)

SBEATS are flared away tangentially from the edge of shoulder over their nominal length of approximately 15 m to provide an offset of 0.3 m from the edge of shoulder to the face of rail at post 1 to minimize potential for damage from snowplows and impacts by errant vehicles.

In vicinity of the approach end of an SBEAT, the roadway is desirably widened beyond the edge of shoulder by at least 1.8 m to accommodate the flaring of the terminal and provide a relatively flat area for impacts by errant vehicles.

In vicinity of the leaving end and constrained approach end of SBEAT, the roadway is widened beyond the edge of shoulder by at least 1.2 m to accommodate the flaring of the terminal and provide a relatively flat area for impacts by errant vehicles.

The area immediately downstream of the first post of an SBEAT or SBT installations measuring 23 m x 6 m should be clear and traversable.

Terminals should be delineated with an Object Marker and Snow Plow Marker placed at the edge of shoulder 2 m in advance of an approach end terminal or 2 m beyond a leaving end terminal to minimize potential for damage from snowplows and impacts by errant vehicles. When terminals are impacted by snowplows or errant vehicles, the terminal system is designed

to release the cable assembly attaching post 1 of a terminal to the w-beam rail, potentially reducing the ultimate tensile capacity of the SBGR installation until repaired.

The Type M SBGR Leaving End Treatment (LET) was developed to maintain the tension in the SBGR system on the leaving end of installations where impacts from opposing direction vehicles are not likely to occur. The W-beam rail between Post 1 and Post 2 is anchored by a 25mm diameter cable attachment to a 1.5m deep post anchor tube at Post 1 as shown in Figure 4-9.

The LET is not designed for end-on opposite direction vehicle impacts. The LET should only be installed on divided highways and one-way ramps. The LET should not be installed on undivided highways, as an approach terminal system, or in any location where the LET is located within the clear zone for opposing traffic.

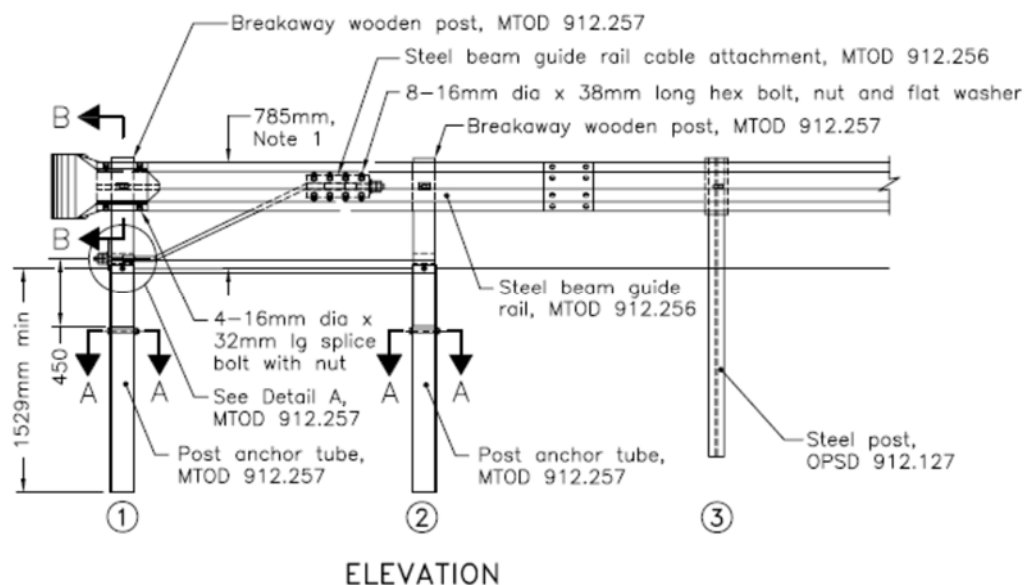

Figure 4-9: Type M20 and M30 SBGR Leaving End Treatment

Openings in Steel Beam Guide Rail

In some cases, it is desirable to provide a short gap in a run of steel beam guide rail to provide pedestrian access to a property, trail or shoreline. These gaps are often constructed in existing runs of guide rail and typically are terminated with a double “fishtail” end treatment which does not provide adequate anchorage and compromises the functioning of the guiderail for a length of several metres on both sides of the gap.

Where a pedestrian gap is required, a 1 metre gap is available for use. This detail has been crash tested to MASH Test Level 2 and requires the construction of twin rounded concrete anchors on either side of the gap. This detail is adequate for use on low-speed roads with

posted speed of less than 70 km/h however it is not recommended for use on high-speed facilities.



Figure 4-10: Pedestrian Gap for Steel Beam Guide Rail

Transitions:

SBGR can be connected directly to rigid barrier systems, as well as to structures, including bridge parapet walls. The standard transition and connection details reduce the likelihood of vehicle snagging, pocketing or penetration. Only standard transition and connection details active in the Contract Preparation System should be used on the provincial highway system.

The standard transitions provide a gradual increase in stiffness from the SBGR system to the rigid structure through use of decreased post spacing, thicker w-beam materials or nested w-beams (double thickness), thicker thrie beam sections, or steel channels. The standard transition is of sufficient length to accommodate changes in deflection characteristics between Type M SBGR and rigid barrier. No gaps or discontinuities are permitted between the approach barrier system and the rigid element.

The connection between Type M SBGR and concrete rigid barriers is accomplished by bolting the W-beam and channel, or thrie beam shoe, to the concrete cross section using through bolts with steel plates on the back side. Different details are used for high speed installations (TL-3) and low speed installations (TL-2) as shown in Figures 4-10, 4-?? and 4-11 respectively. Both approach and leaving end transitions and connections on undivided highways are the same other than beams are lapped in direction of traffic in the adjacent lane.

The leaving ends of structures and rigid barrier systems on divided highways do not normally require the installation of a leaving end SBGR, or a transition to such a system unless required to shield other obstacles or high fill embankments. Where protection is necessary, a standard

W-beam shoe is bolted to the rigid barrier using through bolts is used. This treatment should not be used on the approach end of connections to rigid barriers.

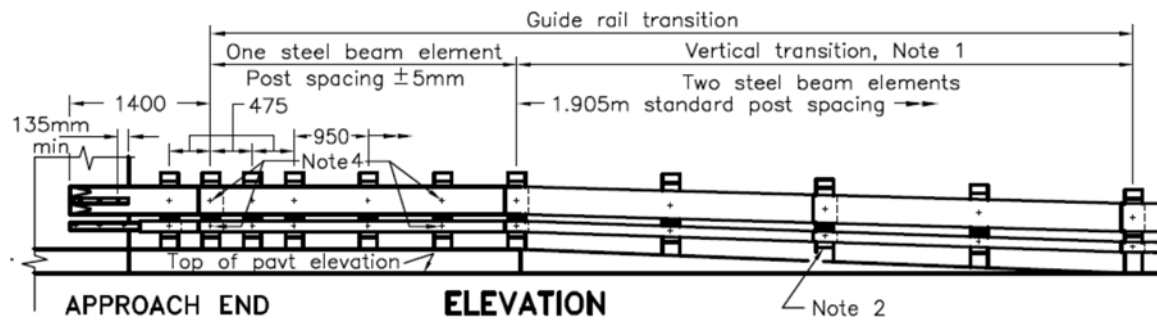

Figure 4-1011: Standard SBGR Connection to Rigid Barrier

See applicable standard for Notes



Figure 4-11: MASH Thrie Beam Structure Connection

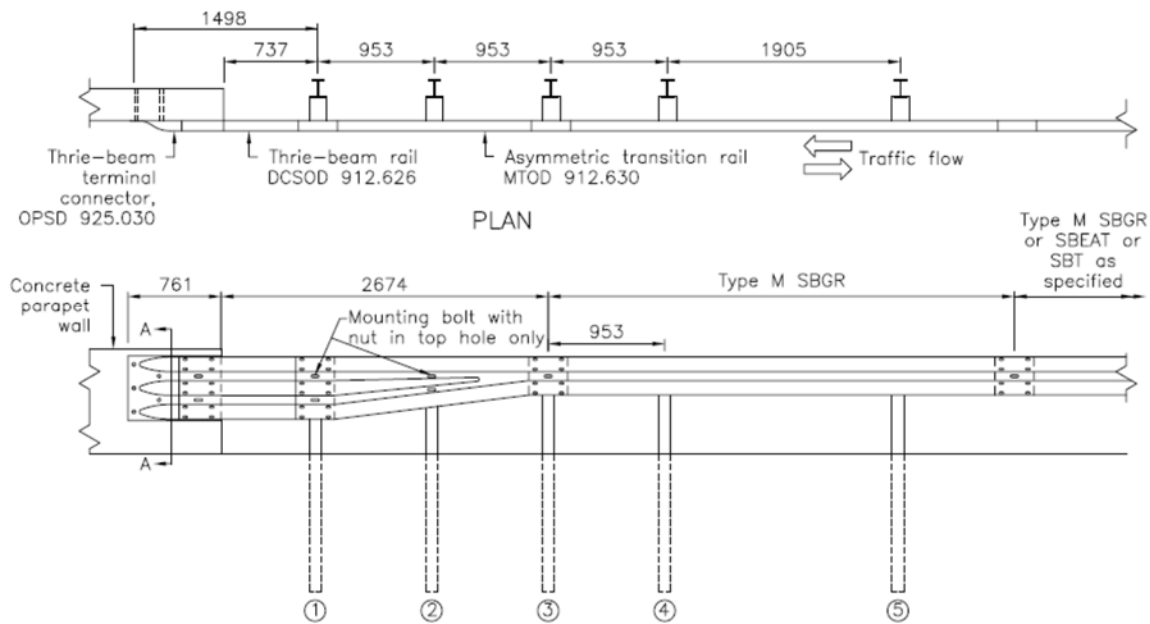

Figure 4-1112: Type M MASH TL-2 SBGR Connection to Rigid Barrier on Low Speed Roads

4.2.2.2 Australian Construction Products Sentry Barrier System

Description:

Australian Construction Products (ACP) Sentry Barrier is a proprietary single rail SBGR that was developed and crash tested by Australian Construction Products. The system when installed into cross-section of various configurations described below meets the crash test acceptance requirements of MASH TL-3.

ACP Sentry Barrier systems uses the same W-beam rail as Type M with a height of 311 mm, a nominal thickness of 2.67 mm (12 gauge) and a length of 3.81m, including the same splicing detail as Type M. Posts are C-shaped steel channels, 72 mm x 115 mm with a specially designed opening to facilitate mounting the rail to the post. Overall system height is 800 mm to the top of the rail with the top of the posts being 10 mm lower than the top of the rail. Rail splices are located at every other post. The system has not been crash tested with splices located mid-span between posts.

The system does not make use of offset blocks. The rail is bolted directly to the C-posts using a bolt, nut and proprietary washer.

The MASH TL-3 working width of Sentry SBGR is 1.59m.

Advantages and Disadvantages:

The advantages of ACP Sentry when compared to Type M SBGR are:

- Narrower profile due to absence of offset blocks;
- 2H:1V slope installations can be installed at the breakpoint; and
- Advantageous for use on rehabilitation projects as they allow for shoulder width to be preserved when roadway grade is raised

The disadvantages of ACP Sentry are:

- Treatment options such as slope installation, long span, reduced post spacing, omitted post and entrances are not currently available;
- Direct connection to rigid barrier not currently available;
- Cannot be installed adjacent to curb and gutter; and
- Higher construction cost

Design Guidance:

Installations must be offset a minimum of 4.25 m from the roadway centerline, to provide clearance for snowplowing operations.

ACP Sentry systems may be installed on the inside and outside of horizontal curves with centerline radii of 45 m or greater. Sharper radius curves require rails to be shop bent at the manufacturer's plant prior to hot dip galvanizing.

The minimum installation length is 30 m including terminals and leaving end treatments, and there is no maximum installation length.

Standard post spacing is 1.905 m. Standard rail mounting height for ACP Sentry measured at face of barrier to top of rail is 800 mm +/- 25 mm.

ACP Sentry SBGR should be installed at the edge of shoulder with 1.0 m rounding, where the breakpoint in rounding to a 6H:1V or flatter granular sideslope is a minimum of 500 mm from the edge of shoulder. The rear (non-traffic side) face of the posts may be placed at the breakpoint of a slope as steep as 2H:1V.

ACP Sentry SBGR may be installed beyond the edge of shoulder when the surface is 10H:1V or flatter, and may be installed with a flare rate up to 10:1.

ACP Sentry posts may be installed into solid rock by drilling or breaking out a hole in the rock to allow rotation of the steel posts during impacts. Post length may also be shortened depending

on the depth of the rock beneath the surface. Installation in asphalt or concrete is not permitted.

Reflectors with a minimum reflective surface of 100 x 100 mm are attached to the sides of the steel C-posts perpendicular to traffic at maximum intervals of 20 m on tangents. On horizontal curves, spacing of reflectors should be reduced according to requirements in OTM Book 11.

End Treatments and Terminals:

Approach and leaving ends of the system installations should be anchored with crashworthy end terminals or leaving end treatments as applicable. A transition to rigid barrier system is not available. Transition to a MASH end treatment requires the use of the 2858mm transition rail detail used to transition MGS guiderail to NCHRP Report 350 guiderail. Sentry SBGR may also be transitioned to MGS guiderail in the same manner.

4.2.2.3 Ingal Civil Products Ezy-Guard 4 Guide Rail

Description

Ingal Civil Products EZY Guard 4 Guide Rail is a proprietary single rail SBGR that was developed, and crash tested by Ingal Civil Products. The system when installed into cross-section of various configurations described below meets the crash test acceptance requirements of MASH TL-3 and NCHRP Report 350 TL-4.

Ezy Guard 4 system uses the same W-beam rail as Type M with a height of 311 mm, a nominal thickness of 2.67 mm (12 gauge) and a length of 3.81m, including the same splicing detail as Type M. Posts are Z-shaped hot rolled flat steel, 50 mm x 90 mm with specially designed resistance and positioning tabs to facilitate mounting the rail to the post. Overall system height is 787 mm to the top of the rail with the top of the posts being 10 mm lower than the top of the rail. Rail splices are located at every other post. The system has not been crash tested with splices located mid-span between posts.

The system does not make use of offset blocks. The rail is attached to the Z-posts using a proprietary Carriage Assembly and bolt.

The MASH TL-3 working width of Ezy Guard 4 SBGR is 1.65m. When installed at the breakpoint of a 2H:1V slope the working width is 1.95m.



Figure 4-~~12~~13: Ingal Civil Ezy Guard 4 System

Advantages and Disadvantages:

The advantages of Ezy Guard 4 when compared to Type M SBGR are:

- Narrower profile due to absence of offset blocks;
- 2H:1V slope installations can be installed at the breakpoint; and
- Advantageous for use on rehabilitation projects as they allow for shoulder width to be preserved when roadway grade is raised

The disadvantages of Ezy Guard 4 are:

- Treatment options such as long span, reduced post spacing, omitted post and entrances are not currently available;
- Direct connection to rigid barrier not currently available;
- Cannot be installed adjacent to curb and gutter; and
- Higher construction cost

Design Guidance:

Installations must be offset a minimum of 4.25 m from the roadway centerline, to provide clearance for snowplowing operations.

Ezy Guard 4 systems may be installed on the inside and outside of horizontal curves with centerline radii of 45 m or greater. Sharper radius curves require rails to be shop bent at the manufacturer's plant prior to hot dip galvanizing.

The minimum installation length is 20 m not including terminals and leaving end treatments, and there is no maximum installation length.

Standard post spacing is 1.905 m. Standard rail mounting height for Ezy Guard 4 measured at face of barrier to top of rail is 787 mm +/- 25 mm.

Ezy Guard 4 SBGR should be installed at the edge of shoulder with 1.0 m rounding, where the breakpoint in rounding to a 2H:1V or flatter granular side slope is a minimum of 500 mm from the edge of shoulder. The rear (non-traffic side) face of the posts may be placed at the breakpoint.

Ezy Guard 4 SBGR may be installed beyond the edge of shoulder when the surface is 10H:1V or flatter and may be installed with a flare rate up to 10:1.

Ezy Guard 4 steel Z-posts may be installed into solid rock by drilling or breaking out a 110 – 300 mm hole. The specifically engineered steel Z-post dissipates energy by yielding through bending near ground level. Because of this, a cut out for post rotation is not necessary. Post length may also be shortened depending on the depth of the rock beneath the surface.

Reflectors with a minimum reflective surface of 100 x 100 mm are attached to the steel Z-posts perpendicular to traffic at maximum intervals of 20 m on tangents. On horizontal curves, spacing of reflectors should be reduced according to requirements in OTM Book 11.

End Treatments and Terminals:

Approach and leaving ends of the system installations should be anchored with crashworthy end terminals or leaving end treatments as applicable. A transition to rigid barrier system is not available. Transition to a MASH end treatment requires the use of the 2858mm transition rail detail used to transition Type M SBGR to NCHRP Report 350 guide rail. Ezy Guard 4 SBGR may also be transitioned to Type M SBGR in the same manner.

Figure 4-~~13-14~~ illustrates the advantage in placing a proprietary blockless SBGR system adjacent to slopes of 3H:1V and 2H:1V slope compared to SBGR M20.

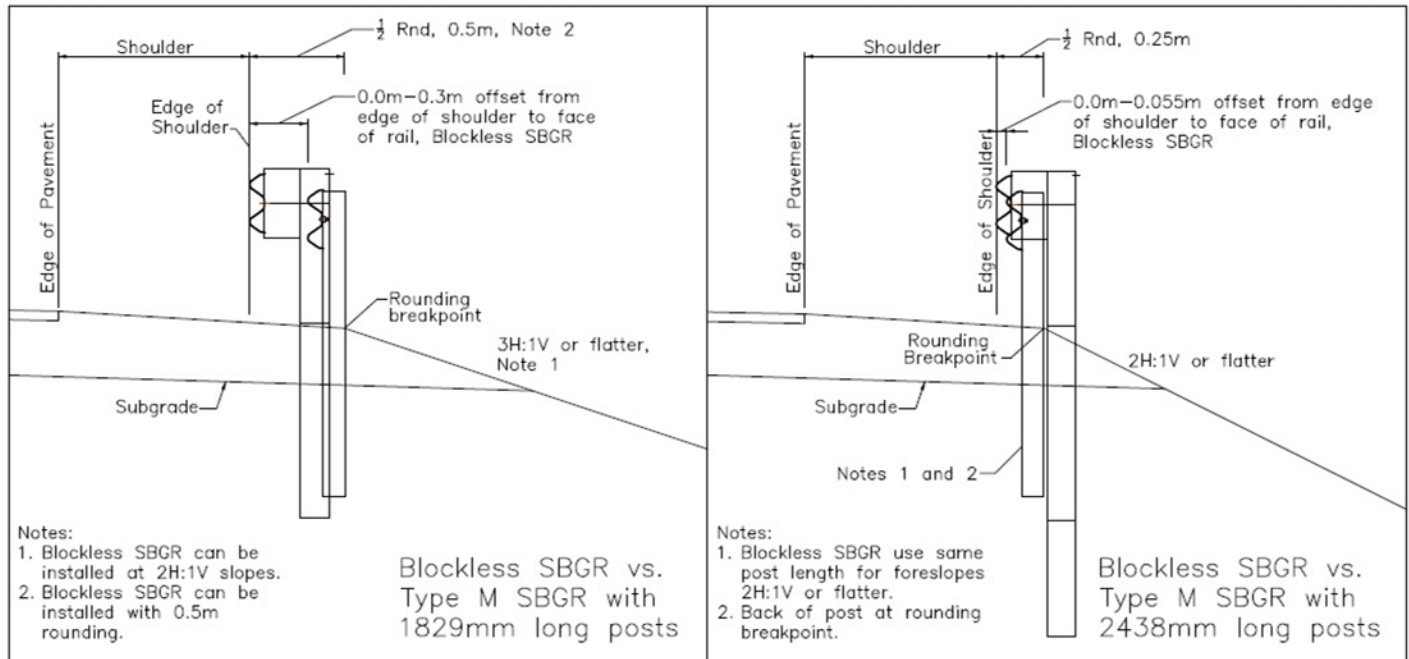

Figure 4-1314: Blockless SBGR Compared to M20 SBGR at Rounding Breakpoint

4.2.3 Concrete Roadside Barrier

All MTO contracts advertised after December 31, 2017 that included new installations of Concrete Roadside Barrier installed on the roadside (eg. not in a median embedded into asphalt on both sides) should have specified Concrete Roadside Barrier in the contract documents.

Description:

Concrete Roadside Barrier (CRB) is a rigid barrier system designed to redirect vehicles through resistance of lateral forces. Generally, rigid barrier systems differ from other barrier systems since they are not designed to yield upon vehicle impact and they do not deflect significantly.

There are various shapes of concrete barriers used throughout North America such as New Jersey shape, F-shape, and constant slope to name a few. In Ontario, the modified New Jersey shape concrete barrier has been used on provincial highways since the early 1990s which has the hinge point between the lower 55° sloped portion of the wall and the upper 1H:10V sloped portion of wall set at a height of 250 mm above the pavement, similar to the F-shape concrete barrier. The original New Jersey shape concrete barrier has the hinge point set at a height of 330 mm above the pavement. The New Jersey shape and F-shape concrete barriers also include a bottom vertical section projecting 75 mm above the asphalt pavement whereas the modified New Jersey concrete barrier used in Ontario does not have the bottom vertical face project above the top of pavement.

F-shape and New Jersey shape median concrete barriers with a minimum height of 810mm (32") meet the crash test acceptance requirements of MASH TL-3 when embedded into asphalt pavement on both sides of the barrier.

For roadside installations of CRB without being embedded into asphalt pavement on the back side of the barrier, steel reinforcement and additional embedment depths into granular base are required in order to meet the crash test acceptance requirements of MASH TL-3. Details for installation of both cast-in-place design and pre-cast CRB are provided in Figure 4-~~14~~15.

Advantages and Disadvantages:

The advantages of CRB when compared to flexible and semi-rigid systems are:

- Lower routine maintenance requirements;
- Minimal dynamic deflection;
- Can be used to shield embankments with a foreslope ratio as steep as 1.5H:1V;
- Can be directly connected to structures; and
- System continues to function properly after most impacts, without any repair required.

The disadvantages of CRB are:

- Limited flexibility to accommodate future pavement overlays while maintaining current test level performance level;
- Does not permit overland drainage flow;
- Storm sewer system is required in most situations;
- Higher repair costs after severe impacts that exceed the performance crash test level; and
- Higher construction costs.

Design Guidance:

Cast-in place CRB may be installed on the inside and outside of horizontal curves with centerline radii of 45 m or greater.

Pre-cast CRB may be installed on the inside and outside of horizontal curves with centerline radii of 90 m or greater. For installations on horizontal curves, the squared ends of each precast unit need to be beveled when cast based on the radii of the curve to provide a good connection with the adjacent pre-cast units.

The minimum installation length is 30 m, and there is no maximum installation length.

Offset from edge of travelled lane should not exceed 4.0 m.

Continuous fully paved surfaces need to be provided between the edge of travelled way and traffic face of CRB with cross-fall not exceeding 10%.

Curbs should not be located between the edge of travelled way and traffic face of CRB.

The CRB design requires a 255 mm embedment into the compacted granular base for additional stability and mass to counteract overturning and sliding. On the backside of CRB, the top of compacted granular base should slope downward at 6% for at least 610 mm to the breakpoint to the 1.5H:1V or flatter granular sideslope. The 1.5H:1V configuration was taken to be the worst case installation scenario during crash testing, and a slope of 2H:1V or flatter is recommended to address erosion concerns. Granular sealing should be provided on granular base for a width of at least 1 m beyond back of CRB.

Precast CRB is fabricated in 4m or 6 m long units. The units are interconnected using a rebar grid that is placed in an open slot that is cast into each end of the CRB unit.

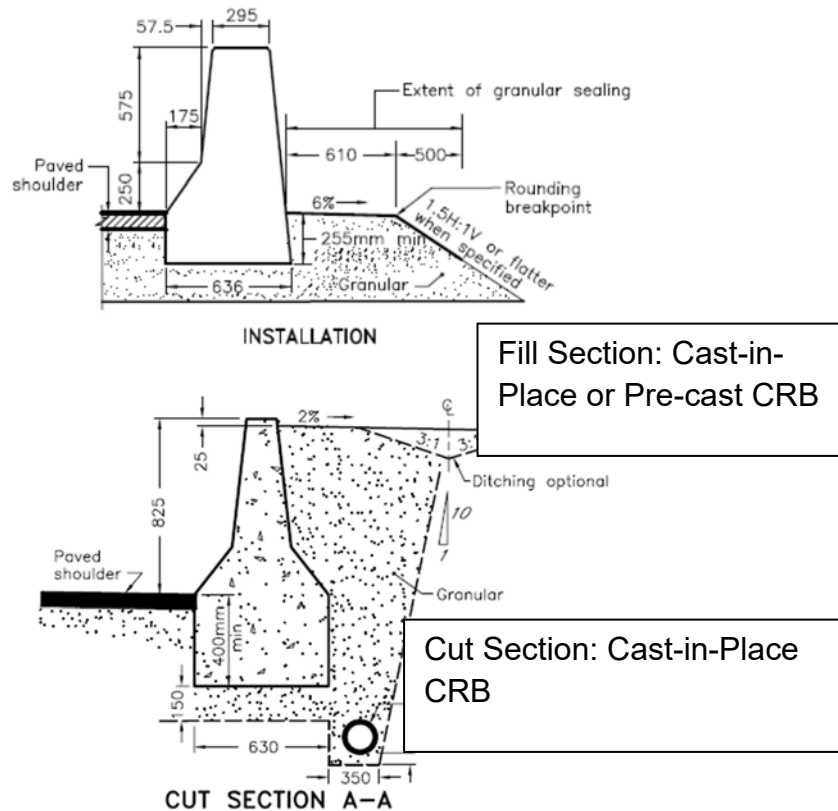

Figure 4-1415: Concrete Roadside Barrier Installations

Following insertion of the rebar grid into the slot, non-shrink grout is placed in the slot to complete the connection.

CRB should not be used in locations where relief flow from an overland flow route will cross the roadway during flood events.

A minimum offset between the toe of the traffic face of the CRB and the face of an obstacle located behind the CRB should be at least 0.8 m to account for potential shifting of CRB during MASH TL-3 impacts (Dynamic deflection of 142 mm reported for pre-cast design).

Approach and leaving ends of the system installations should be shielded with an appropriate end treatment or transitioned to / from another roadside barrier system.

CRB is cost effective on high volume, high-speed roadways where there is a high frequency of collisions since maintenance and repair of CRB after most impacts is minimal when compared to semi-rigid and flexible systems. CRB is preferable in locations where the system will be installed close to the traveled way, where site access is limited, and/or where lane closures for repairs would be costly and disruptive.

CRB performs all of the drainage functions of a curb and gutter system, and edge of catch basin grates should be offset 125 mm from toe of CRB.

For cut-installations, only cast-in-place CRB option is currently available as shown in Figure 4-1415.

End Treatments:

The blunt end or tapered down end of any rigid barrier system is a hazard if it is located where it may be hit by an errant vehicle. Each end of the CRB system, when not transitioned to another barrier system should shielded with a single sided energy attenuator at the following locations:

- Approach end on divided highways and one-way ramps;
- Approach and leaving end on undivided highways and two-way ramps; and
- Left (median) shoulder on the leaving end on divided highways when the leaving end is located within the clear zone for opposing traffic.

Acceptable single sided attenuators that meet the crash test acceptance requirements of NCHRP Report 350, TL-3 are as follows:

- Box Beam Bursting Energy Attenuating Terminal (BB-BEAT)
- QuadTrend

Additional details for each system are provided in Section 4.4.

Transitions:

CRB can be connected to semi-rigid barrier systems and other rigid barrier systems including concrete bridge rails.

The standard transition and connection details for CRB connections to semi-rigid barriers are described in Section 4.2.

Standard transitions provide a gradual increase in stiffness from the SBGR system to the CRB. The standard transition should be of sufficient length to accommodate changes in deflection characteristics, shape and height, between the two systems. No gaps or discontinuities are permitted between the approach SBGR and CRB.

4.2.4 Thrie Beam Systems

Thrie beam roadside barriers provide a higher performing alternative to a traditional W-beam system. A thrie beam rail resembles a W-beam rail however it has three ridges and two valleys compared to the two ridges and one valley of a W-beam. A standard thrie beam rail is the same 4,128 mm length as a standard W-beam rail and has a height of 508 mm compared to the 311 mm height of W beam.

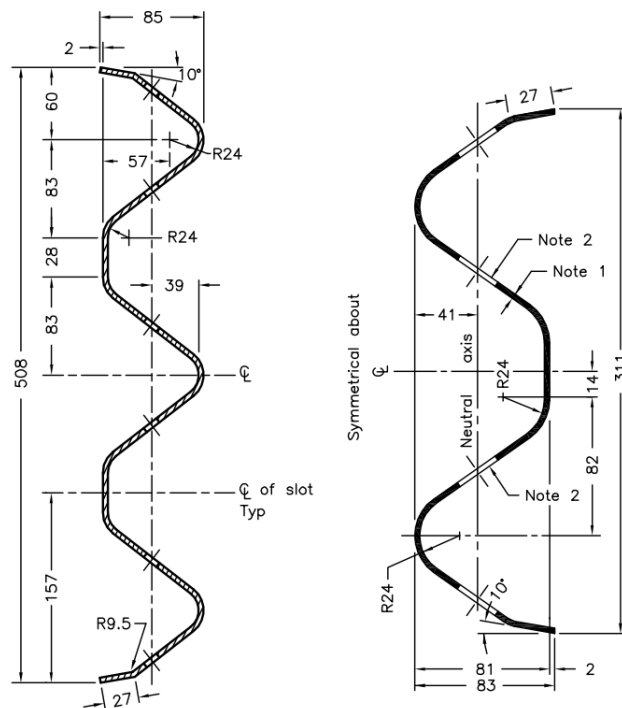

Figure 4-16: W-Beam and Thrie Beam Cross Section Comparison

Thrie beam roadside barriers are crash tested to MASH Test Level 4 and thus provide superior performance compared to their W beam counterparts. MASH Test Level 4 systems are able to contain and redirect a 10,000 kg single-unit truck at an impact angle of 15 degrees and a speed of 90 km/h, in addition to meeting the Test Level 3 requirements. They are not intended to redirect tractor-semitrailers as Test Level 5 barriers are capable of however, they may provide some enhanced capabilities in partially containing such vehicles in less severe impacts. The disadvantage of these systems is the additional installation cost however this may be partially offset by reduced maintenance costs as these systems are less likely to be significantly damaged in minor impacts with lighter vehicles compared to TL-3 systems.

Thrie beam roadside barriers should be considered on roads with commercial traffic volumes in excess of 7,000 vehicles per day.

Approach and leaving ends of thrie beam system installations must be transitioned to a TL-3 W-beam system before being terminated with an appropriate end treatment. Transitions should be constructed beyond the calculated length of need where TL-4 barrier required to shield an area of concern.

4.2.4.1 Australian Construction Products TL-4 Barrier

Description

ACP TL-4 barrier is a proprietary single rail thrie beam barrier that was developed and crash tested by Australian Construction Products. The system when installed in a roadside configuration meets the crash test acceptance requirements of MASH TL-3 and TL-4.

ACP TL-4 Barrier uses a standard thrie beam rail with a height of 506 mm, a nominal thickness of 2.67 mm (12 gauge) and a length of 3.81m, with a standard splicing detail. Posts are C-shaped steel channels, 72 mm x 115 mm and 2,000 mm in length with a specially designed opening to facilitate mounting the rail to the post. Overall system height is 1,050 mm to the top of the rail with the top of the posts being 10 mm lower than the top of the rail. The system width is 200 mm. Rail splices are located at every other post. The system has not been crash tested with splices located mid-span between posts.

The system does not make use of offset blocks. The rail is bolted directly to the C-posts using a bolt, nut, and proprietary washer.

ACP TL-4 SBGR should be installed at the edge of shoulder with 1.0 m rounding, where the breakpoint in rounding to a 3H:1V or flatter granular sideslope is a minimum of 500 mm from the edge of shoulder. The minimum distance from the rear face of the post to the rounding breakpoint is 400 mm when TL-3 performance is required and 1,530 mm when TL-4 performance is required.



Figure 4-17: ACP TL-4 Barrier

The MASH TL-3 working width of the ACP TL-4 barrier is 1.45m. The MASH TL-4 working width is 1.53 m.

Reflectors with a minimum reflective surface of 100 x 100 mm are attached to the sides of the steel C-posts perpendicular to traffic at maximum intervals of 20 m on tangents. On horizontal curves, spacing of reflectors should be reduced according to requirements in OTM Book 11.

4.2.4.2 Ezy Guard High Containment Barrier

Description

The Ezy Guard High Containment barrier is a proprietary single rail three beam barrier that was developed and crash tested by Ingal Civil Products of Australia. The system when installed in a roadside configuration meets the crash test acceptance requirements of MASH TL-3 and TL-4.

The Ezy Guard High Containment barrier uses a standard three beam rail with a height of 506 mm, a nominal thickness of 2.67 mm (12 gauge) and a length of 3.81m, with a standard splicing detail. Posts are hot-rolled flat steel Z-shapes with specially designed resistance and positioning tabs to facilitate mounting the rail to the post, 140 mm x 60 mm and 2,000 in length. Overall

system height is 980 mm to the top of the rail with the top of the posts being 10 mm lower than the top of the rail. The system width is 248 mm. Rail splices are located at every other post. The system has not been crash tested with splices located mid-span between posts.

The system does not make use of offset blocks. The rail is attached to the Z-posts using a proprietary Carriage Assembly and bolt.

Ezy Guard High Containment should be installed at the edge of shoulder with 1.0 m rounding, where the breakpoint in rounding to a 3H:1V or flatter granular sideslope is a minimum of 500 mm from the edge of shoulder. The minimum distance from the rear face of the post to the rounding breakpoint is 1,770 mm.

The MASH TL-3 working width of the ACP TL-4 barrier is 1.36 m. The MASH TL-4 working width is 2.46 m.

Reflectors with a minimum reflective surface of 100 x 100 mm are attached to the sides of the steel Z-posts perpendicular to traffic at maximum intervals of 20 m on tangents. On horizontal curves, spacing of reflectors should be reduced according to requirements in OTM Book 11.



Figure 4-18: Ezy Guard High Containment Barrier

4.3 Median Barrier Systems

A median barrier system is designed to redirect vehicles that may impact either side of the barrier system. The primary purpose of a median barrier system is to reduce the potential for and severity of cross-median collisions. Medians are typically used to separate the travelled ways for traffic in opposing directions, or to separate the travelled ways to manage access (e.g. core-collector systems or service roads).

The following median barrier systems have been implemented for installation as new median barrier systems on Provincial Highways:

Flexible Median Barrier Systems:

- High Tension Four-Cable Median Guide Rail (HT4CMGR)

Semi-Rigid Median Barrier Systems:

- Type M Double Rail Steel Beam Guide Rail (Type M SBGR)
- Australian Construction Products Sentry Median Guide Rail
- Ingal Civil Products Ezy-Guard 4 Median Guide Rail
- Guardian 5 Steel Beam Median Barrier

Rigid Median Barrier Systems:

- Type M Median Concrete Barrier (Type M MCB)
- Type TW Median Concrete barrier (Type TW MCB)

Description and design guidance for each barrier system are described in the applicable sections.

4.3.1 High Tension Four Cable Median Guide Rail Systems

Description:

High Tension 4-Cable Median Guide Rail (HT4CMGR) systems are proprietary flexible barrier systems with wire ropes that are pre-tensioned to significantly higher tension values than cables for low tension systems used throughout Ontario since the 1960s. The HT4CMGR cables are 19 mm diameter, 3 by 7 construction steel wire rope according to AASHTO M 30 with a minimum breaking strength of 173.5 kN, and Type I Class A zinc coating.

HT4CMGR has been installed on Highway 401 between London and Tilbury to mitigate cross-median collisions. Two systems are currently available which have met the crash test acceptance requirements of NCHRP Report 350 and MASH-09 TL-3 and will be further crash tested in accordance with the updated requirements of MASH-16. The systems are the Gregory Safence 4-Cable and Trinity CASS S3 4-Cable.

Advantages and Disadvantages:

Advantages of HT4CMGR installations when compared to semi-rigid and rigid barrier systems are:

- Lower supply and installation costs;
- Less visual obstruction;
- Suited for open areas where blowing snow may cause drifting;
- Can be installed within wide depressed medians ranging in width from 10.5 m (assuming 1.0 m wide median shoulders) to over 23 m with 4H:1V or flatter slopes. Semi-rigid and rigid systems have to be installed adjacent to median shoulders and can't be installed on 4H:1V or 6H:1V median slopes common in Ontario.
- Installations within medians provide increased offset from one or both travelled ways compared to installations immediately adjacent to median shoulders, likely resulting in significantly fewer vehicular impacts;
- System will continue to function after impacts where several posts have been damaged as tension in system should keep cables at proper mounting heights; and
- More forgiving due to lower deceleration forces sustained by vehicle and occupants during impact.

Disadvantages of HT4CMGR installations when compared to semi-rigid and rigid barrier systems are:

- Higher dynamic deflection and working width requires larger clear area behind the system;

- Cable tension needs to be monitored;
- No transitions currently available for interconnection with other systems;
- More susceptible to damage from minor collisions; and
- Impacts into terminal may result in entire system becoming non-functional until repaired.

Design Guidance:

HT4CMGR installations in medians with 4H:1V slopes should be offset a maximum of 1.2 m from one of the shoulder rounding breakpoints, and a minimum of 2.5 m from the toe of the 4H:1V slope. Based on this configuration with 1.0 m wide median shoulders and 1.0 m wide roundings, minimum median width is 10.32 m. See Figure 4-~~15~~-19 for details.

HT4CMGR installations in medians with 6H:1V slopes should be offset a minimum of 2.5 m from the toe of one of the 6H:1V slopes, and no offset requirements from either shoulder rounding breakpoint. Therefore minimum median width would be similar to the 4H:1V median described above, and wider medians would allow placement of the system further away from one of the shoulder rounding breakpoints to further reduce probability of impacts.

HT4CMGR may also be installed in medians with 4H:1V slopes on one side, and 6H:1V slopes on opposite side using guidance from above for determining optimum location of system on either slope.

HT4CMGR may also be installed in medians with 4H:1V or flatter slopes with flat bottom ditches using guidance from above for determining location of system from toe of either slope

HT4CMGR systems may be installed on the inside and outside of horizontal curves with centerline radii of 400 m or greater. On rural freeways, minimum horizontal curve radii are typically larger than 650 m, with many freeways in Ontario having horizontal curves of 1745 m (1 degree) or flatter.

For installations on horizontal right curves, the HT4CMGR system should be installed on the left side of the median ditch. For installations on horizontal left curves, the HT4CMGR system should be installed on the right side of the median ditch.

The recommended minimum length of a HT4CMGR system is 100 m including terminals, and the maximum proposed installation length is currently 6,000 m including terminals. Successful installations longer than 6,000 m are reported by several manufacturers.

Each HT4CMGR system uses four 19 mm diameter pre-stretched cables mounted within and/or attached to face of proprietary galvanized steel line posts with various foundation options

spaced at intervals ranging from 2 m to 5 m, dependent on desired working width required. Each cable is tightened to the manufacturer's specified tension typically ranging from 20 kN to 40 kN dependant upon the temperature of the cable. At 20⁰ C, cable tension should be 13.7 kN.

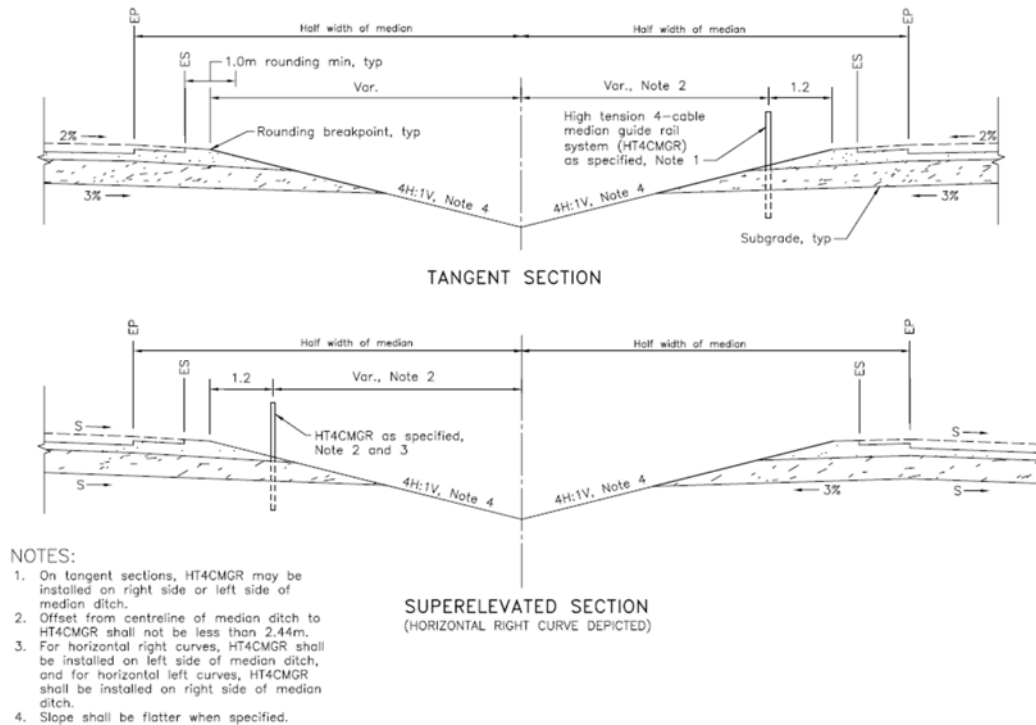

Figure 4-1519: Typical HT4CMGR installation for rural median with 4H:1V slopes

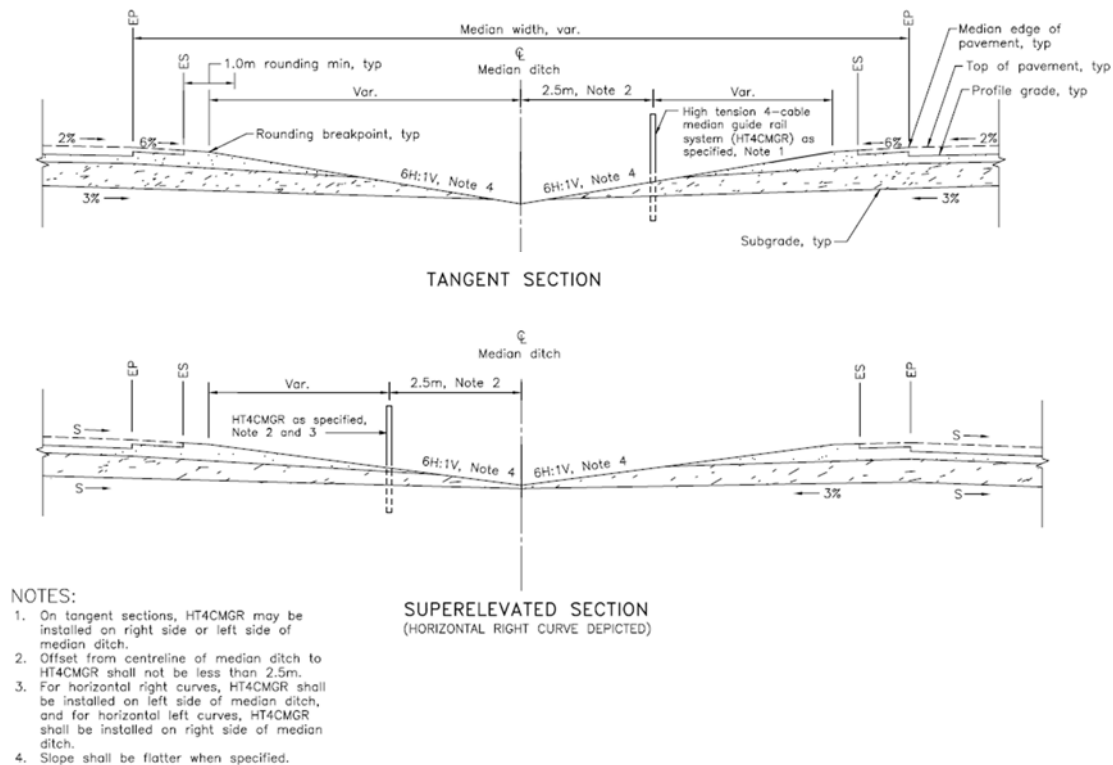

Figure 4-1620: Typical HT4CMGR installation for rural median with 6H:1V slopes

Turnbuckles are used to achieve the specified tension in the cables according to Contract Documents and manufacturer's instructions. Turnbuckles should be installed at 305 m intervals, and may be located above one another (eg. all four could be located above each other between same posts).

Modified HT4CMGR line posts may be installed over shallow culverts or other buried obstacles dependent on guidance from each manufacturer.

Length of need for the HT4CMGR system is dependent on type of system and terminal.

HT4CMGR installations should not be installed in front of or behind curbs.

When offset 1.22 m or more from the shoulder breakpoint, which is at least 2.72 m from edge of median shoulder assuming 1.0 m wide median shoulders and 1.0 m roundings, reflectors are not recommended. Shoulder rumble strips and post mounted delineators or snowplow markers should continue to be installed along each side of median according to current MTO requirements.

Crashworthy proprietary end terminals should be installed on 6H:1V or flatter slopes as described below.

End Treatments and Terminals:

Crashworthy proprietary end terminals should be installed on 6H:1V or flatter slopes at least 2.44 m from the toe of slope which also intersects the opposite slope that is 4H:1V or flatter. The Gregory Safence 4-Cable barrier is terminated with the Safence Terminal while the Trinity CASS S3 4-Cable system is terminated using the Trinity HARP Terminal. Both systems meet the crash testing requirements of NCHRP Report 350 TL-3.

The area immediately downstream of the terminal anchor assembly measuring 23 m x 6 m should be clear and traversable.

Terminals should be delineated with an Object Marker and Snow Plow Marker placed 0.6 m from edge of closest shoulder breakpoint 2 m in advance of an approach end terminal or 2 m beyond a leaving end terminal to minimize potential for damage from snowplows and impacts by errant vehicles. When terminals are impacted by snowplows or errant vehicles, the terminal system is designed to release the cables during impacts, making the entire length of the HT4CMGR installation non-functioning until repaired.

Transitions:

There are currently no acceptable transitions available for transitioning and connecting HT4CGR to semi-rigid barriers or rigid barrier systems.

Terminating HT4CMGR systems in vicinity of bridges or overpasses will need to overlap with semi-rigid barriers or rigid barrier systems terminated with a crashworthy terminal. Systems cannot be interconnected.

4.3.2 Type M Double Rail Steel Beam Guide Rail

Semi-rigid median barrier systems are generally only installed on freeways within narrow medians less than 10 m wide as an alternative to concrete median barrier when a permeable barrier system is required to not block overland flow routes where relief flow is required across a roadway during flood events.

Type M double rail SBGR when posts are installed behind curb meets the crash test acceptance requirements of NCHRP Report 350 TL-3 and is expected to be crash tested to MASH in the coming years.

Description:

Type M double rail SBGR is similar to Type M SBGR described earlier in section 4.2.2 other than it has two standard W-beam rails mounted to two standard 30 cm deep routed wooden or plastic offset blocks attached to each side of the standard 1829mm long W150x13 steel posts spaced at 1.905 m intervals. The top of rail height is the same as Type M SBGR with top of rail set at 785 mm +/- 25 mm.

• **Advantages and Disadvantages:**

The main advantages of Type M double rail SBGR are:

- Lower construction cost than rigid systems;
- Permeable barrier system which should not block overland flow routes where relief flow is required across a roadway during flood events.

The main disadvantages of Type M double rail SBGR are:

- Higher maintenance requirements compared to rigid systems;
- Higher dynamic deflection than rigid systems;
- Will not block potential headlight glare from opposing traffic;
- Steel posts will potentially conflict with buried drainage systems and require curbs to direct surface drainage away from posts longitudinally along median to catch basins;
- Will not accommodate installation of small signs, luminaires, or large sign support legs; and
- Lower performance crash test level than TL-5 tall wall median barrier and 4.3.2.2 Guardian 5 Steel Beam Median Barrier.

Design Guidance:

Much of the design guidance for Type M SBGR provided in section 4.2.2 applies to Type M double rail SBGR.

Type M double rail SBGR may be installed beyond the edge of median shoulders when the surface is 10H:1V or flatter, and may be installed with a flare rate up to 10:1. Steel posts should not be set at bottom of two intersecting 10H:1V slopes which will likely function as a drainage swale.

For narrow medians where adjacent lanes drain towards the median, Type M double rail SBGR should be installed within a raised island with face of curbs offset no greater than 125 mm in front of each w-beam rail. The centre of raised island should not be paved with asphalt or concrete, and should be backfilled with compacted granular base and treated with granular sealant. Figure 4-~~17~~21 shows configuration.

Reflectors with a minimum reflective surface of 100 x 100 mm and flexibility to bend 90 degrees from vertical and self-restore are attached to the top of the Type M steel posts at maximum intervals of 20 m on tangents. On horizontal curves, spacing of reflectors should be reduced according to requirements in OTM Book 11.

Approach and leaving ends of the system installations should be transitioned from/to rigid barrier systems or terminated with a median end terminal or crash cushion.

~~Specifying a double sided crash cushion will require a non-standard design being issued by Design and Contract Standards Office.~~

End Treatments and Terminals:

In order to allow development of tensile strength in the Type M double rail SBGR system, both ends of the system installation need to be transitioned and anchored to a rigid barrier system, or transitioned and anchored to an appropriate double sided crash cushion. Both situations will require a non-standard design to be issued by ~~Design and Contract Standards~~Highway Design Office.

4.3.3 Australian Construction Products Sentry Median Barrier W Beam System

Description:

ACP Sentry Median Barrier is a double-sided version of the ACP Sentry barrier that meets the crash test acceptance requirements for MASH TL-3. The barrier consists of the same posts, rails and mounting hardware as the roadside version, with two rails mounted back-to-back to every other post.



Figure 4-~~1721~~: ACP Sentry W Beam Median Barrier

The median system may be installed in a granular or asphalt median and has a working width of 1.49m. When a granular median is used, granular sealing shall be applied as appropriate to mitigate erosion and gravel tracking onto the roadway. The median must be flush, the system may not be installed adjacent to barrier curb.

Design Guidance:

ACP Sentry Median SBGR may be installed beyond the edge of median shoulders when the surface is 10H:1V or flatter, and may be installed with a flare rate up to 10:1. Steel posts should

not be set at bottom of two intersecting 10H:1V slopes which will likely function as a drainage swale.

ACP Sentry Median SBGR is not tested in conjunction with concrete curb and gutter and should only be installed in flush medians. Medians may be granular or asphalt with leave-outs cut to allow for post rotation. Exposed granular surfaces should have granular sealing applied to prevent erosion.

Reflectors with a minimum reflective surface of 100 x 100 mm and flexibility to bend 90 degrees from vertical and self-restore are attached to the top of the C-posts at maximum intervals of 20 m on tangents. On horizontal curves, spacing of reflectors should be reduced according to requirements in OTM Book 11.

Transitions and End Treatments:

The Sentry Median Barrier may be anchored with either a compatible crash cushion or a Median SBEAT. A transition is required to double-sided conventional guiderail with offset blocks.

4.3.4 Ingal Civil Products Ezy Guard 4 Median Barrier W Beam System

Description:

Ingal Civil Products Ezy Guard 4 Median Barrier is a double-sided version of the Ingal Civil Products Ezy Guard 4 barrier that meets the crash test acceptance requirements for MASH TL-3. The barrier consists of the same posts, rails and mounting hardware as the roadside version, with two rails mounted back-to-back to every other post.



Figure 4-~~18-22~~ Ingal Civil Products Ezy Guard 4 W Beam Median Barrier

The median system may be installed in a granular or asphalt median and has a working width of 1.65m. When a granular median is used, granular sealing shall be applied as appropriate to mitigate erosion and gravel tracking onto the roadway. The median must be flush, the system may not be installed adjacent to barrier curb.

Design Guidance:

Ingal Civil Products Ezy Guard 4 Median SBGR may be installed beyond the edge of median shoulders when the surface is 10H:1V or flatter, and may be installed with a flare rate up to 10:1. Steel posts should not be set at bottom of two intersecting 10H:1V slopes which will likely function as a drainage swale.

Ingal Civil Products Ezy Guard 4 Median SBGR is not tested in conjunction with concrete curb and gutter and should only be installed in flush medians. Medians may be granular or asphalt and do not require leave-out cut to allow for post rotation. Exposed granular surfaces should have granular sealing applied to prevent erosion.

Reflectors with a minimum reflective surface of 100 x 100 mm and flexibility to bend 90 degrees from vertical and self-restore are attached to the top of the steel Z-post at maximum intervals of 20 m on tangents. On horizontal curves, spacing of reflectors should be reduced according to requirements in OTM Book 11.

Transitions and End Treatments:

The Ingal Civil Products Ezy Guard 4 Median Barrier may be anchored with either a compatible crash cushion or a Median SBEAT. A transition is required to double-sided conventional guide rail with offset blocks.

4.3.5 Guardian 5 Steel Beam Median Barrier

The Guardian 5 Steel Beam Median Barrier (G5) system was developed and successfully crash tested in 2016 to meet the crash test acceptance requirements of MASH TL-5.

Description:

ArcelorMittal and Gregory Industries developed their proprietary G5 steel beam median barrier system to meet the requirements of MASH TL-5. The system uses 3 m long high strength steel C posts spaced at 1.52 m intervals (vs 1.905 m for SBGR) with high strength thrie beam and w-beam rails mounted on steel offset blocks on each side. While these beams have the same geometry and appear to be similar to standard thrie beam and w-beam rails, they are 4.572 m long whereas standard rails are 3.810 m long. Having different post spacing and rail lengths from Type M SBGR will ensure that during installation only the longer high strength steel rails will attach to the posts. (eg., standard strength rails cannot mistakenly be used in field).

For the G5 steel beam median barrier system, the top of the w-beam rail is set 1513 mm above the pavement, whereas the top of the thrie beam is set at 894 mm above the pavement.

Dynamic Deflection and Working Width results from the MASH crash tests are summarized in Table 4-2.

• **Advantages and Disadvantages:**

The main advantages of —G5 steel beam median barrier are:

- Similar construction cost to tall wall median concrete barrier;
- Higher performance test level than Type M double rail SBGR and HT4CMGR systems;

- Taller system results in reduced zone of intrusion for tractor trailers during TL-5 impacts when compared to tall wall median concrete barrier;
- Permeable barrier system which should not block overland flow routes where relief flow is required across a roadway during flood events;
- Taller height of system may eliminate more headlight glare than tall wall concrete median barrier (1513mm vs 1050 mm); and
- More forgiving than rigid tall wall median concrete barrier due to lower deceleration forces sustained by vehicle and occupants during impact.

The main disadvantages of G5 steel beam median barrier are:

- Higher maintenance requirements than rigid systems;
- Will not accommodate installation of small signs, luminaires, or large sign support legs; and
- Longer steel posts will potentially conflict with buried drainage systems and require curbs to direct surface drainage away from posts longitudinally along median to catch basins.
- Can't be installed in stepped medians which are common on superelevated horizontal curves.

Design Guidance:

Minimum installation length is 100 m.

MASH Crash Test	Test Vehicle	Impact Speed km/h	Impact Angle Degrees	Dynamic Deflection m	Working Width m
3-10	1100C	101	25.3	0.31	0.31
3-11	2270P	100	25.1	0.49	0.49
5-12	36000V	78.5	15.1	1.32	1.65

Table 4-2: Working Widths for Guardian 5 Steel Beam Median Barrier

System may be installed beyond the edge of median shoulders when the surface is 10H:1V or flatter. Steel posts should not be set at bottom of two intersecting 10H:1V slopes which would likely function as a drainage swale.

For narrow medians where adjacent lanes drain towards the median, system should be installed within a raised island with face of curbs offset no greater than 125 mm in front of each three-beam rail. The centre of raised island should not be paved with asphalt or concrete, and should be backfilled with compacted granular base and treated with granular sealant.

Retroreflective tape with a minimum reflective surface of 100 x 100 mm should be attached to the sides of the steel c-post between upper and lower beams at maximum intervals of 20 m on tangents. On horizontal curves, spacing of reflectors should be reduced according to requirements in OTM Book 11.

Approach and leaving ends of the system installations should be transitioned from/to tall wall concrete median barrier, or terminated with a double sided crash cushion.

Specifying a double sided crash cushion will require issuance of a non-standard design for the G5 steel beam median barrier system by ~~Design and Contract Standards~~Highway Design Office.



Figure 4-~~1923~~: Guardian 5 Steel Beam Median Barrier System

Photo courtesy of Gregory Steel, Inc.

End Treatments and Terminals:

In order to allow development of tensile strength in the G5 steel beam median barrier system, both ends of the system installation need to be transitioned and anchored to a rigid barrier system, or transitioned and anchored to an appropriate double sided crash cushion. Both situations will require non-standard design to be issued by ~~Design and Contract Standards~~Highway Design Office.

4.3.6 Concrete Median Barrier

Concrete Median Barriers (CMB) are rigid barrier systems designed to redirect vehicles through resistance of lateral forces. Generally, rigid barrier systems differ from other barrier systems since they are not designed to yield upon vehicle impact and they do not deflect.

Concrete median barriers are the most commonly used type of median barrier in Ontario. The prevalence of CMB is due mainly to its low life-cycle cost, effective performance, and low maintenance characteristics, which make it suitable for high speed high volume highways with narrow medians. For opposing directions of travel on freeways with narrow medians, tall wall concrete median barrier should be used which meets MASH TL-5.

CMBs are typically classified by their shape and overall height above top of pavement.

Description:

The modified New Jersey shape concrete barrier has been used for all new installations of concrete median barrier since the early 1990s on the provincial highway system. For additional information about modified New Jersey shape concrete barriers, refer to Section 4.2.3.

Standard heights of CMB used on the provincial highway system are 825 mm and 1050 mm, which is measured from top of adjacent pavement to the top of barrier. These heights do not include the embedded part of the CMB below the top of pavement.

Slip-formed or cast-in-place 825 mm high Type M CMB and Type C CMB, and 1050 mm high Type TW CMB, also known as Ontario Tall Wall, specified on MTO contracts advertised after December 31, 2017 will meet the crash test acceptance requirements of MASH TL-3 and TL-5 respectively.

All three CMB configurations referenced above may be constructed in an asymmetric configuration to accommodate grade differentials typically found between opposing lanes on superelevated curves. The maximum grade differential that can be accommodated is 600 mm.

4.3.6.1 Type TW Concrete Median Barrier

Advantages and Disadvantages:

The advantages of Type TW CMB are:

- Lower maintenance requirements compared to flexible and semi-rigid systems;
- Higher profile addresses headlight glare;
- No dynamic deflection;
- Can be directly connected to structures with concrete TL-5 bridge rails; and
- System can function properly after moderate impacts.

The disadvantages of Type TW CMB compared to semi-rigid and flexible barrier systems are:

- Less forgiving due to higher deceleration forces sustained by vehicle and occupants during impacts;
- Closed drainage system required below barrier to accommodate drainage from median shoulders and lanes draining towards median;
- Will block overland flow in flood prone areas;
- May limit stopping sight distance on inside of horizontal curves with narrow median shoulders, especially when asymmetric CMB required.
- Construction cost is higher relative to semi-rigid median barrier systems; and
- After severe impacts by trucks, expensive repairs may be required to restore CMB.

Design Guidance

Type TW CMB is the desired median barrier system for installation on freeways with narrow medians less than 10 m wide, except where overland flow needs to be accommodated.

Type TW CMB may also be installed on freeways with narrow medians between core/collector systems, or between freeways and service roads.

The minimum installation length is 30 m, and there is no maximum installation length.

The traversable area between the travelled way and the barrier should be free of obstacles and irregularities, and be sloped no steeper than 10H:1V. This area should be paved, with a minimum depth of 75 mm over a width of at least 3.0 m on both sides of the TW CMB.

Approach and leaving ends of the system installations should be shielded with an appropriate end treatment or transitioned to / from another roadside barrier system.

Type TW CMB should not be installed more than 4.6 m from the edge of the travelled way. An exception is on the inside of horizontal curves, where it is necessary to maintain minimum stopping sight distance. Installation at greater offsets is generally not desirable as the cost of shoulder paving and maintenance becomes excessive.

Curbs should not be installed in front of CMB.



Figure 4-~~2023~~2024: Tall Wall Concrete Median Barrier installation

End Treatments:

The blunt end of any rigid barrier system is a hazard if it is located where it may be hit by an errant vehicle. Each end of Type TW CMB system should be transitioned to a narrower CMB or treatment and terminated with an appropriate crash cushion.

Transitions:

Both approach and leaving end connections should conform to standard transition design requirements.

Standard designs are being finalized in 2018 for transitioning TW CMB to Guardian G5 Steel Beam Median Barrier system. Standard designs are currently available for connecting TW to TL-5 concrete bridge rails.

4.3.6.2 Type M and C Concrete Median Barrier

The 825 mm high Type M and C CMB are non-reinforced concrete median barrier systems. Type M and C CMBs are typically used as a separator barrier between two adjacent roadways with traffic flows in the same direction, such as core/collector systems.

Advantages and Disadvantages:

The advantages of Type M and C CMB compared to semi-rigid and flexible barrier systems are:

- Lower routine maintenance requirements when compared to semi-rigid systems;
- No dynamic deflection;
- Can be used on horizontal curves;
- Can be connected to structures; and
- System continues to function properly after most minor impacts, without any repair required.

The disadvantages of Type M and C compared to semi-rigid and flexible barrier systems are:

- Does not permit overland drainage flow;
- Storm sewer system is required in most situations; and
- Construction cost is higher relative to semi-rigid systems.

Design Guidance

There is no maximum installation length. The minimum installation length is 30 m.

The traversable area between the travelled way and the barrier should be free of obstacles and irregularities, and be sloped no steeper than 10H:1V. This area should be paved.

Approach and leaving ends of the system installations should be shielded with an appropriate end treatment or transitioned to / from another roadside barrier system.

Type M and C CMB is effective on high volume, high-speed roadways where there is a high frequency of collisions since routine maintenance is typically less for a rigid barrier system when compared to semi-rigid systems. Therefore, Type M and C is desirable in locations where the system will be installed close to the traveled way, where site access is limited, and/or where lane closures are costly and disruptive.

Paving of the adjacent shoulder is required to embed the CMB to prevent deflection of system when impacted.

Type M and C CMB should not be installed more than 4.6 m from the edge of the travelled way. An exception is on the inside of horizontal curves, where it may be necessary to maintain stopping sight distance. Installation at greater offsets is generally not desirable as the cost of shoulder paving becomes excessive.

Type M and C CMB performs all of the drainage functions of a curb and gutter system. Curb and gutter should not be located between the edge of travelled way and traffic face of CMB.

End Treatments

The blunt end of any rigid barrier system is a hazard if it is located where it may be hit by an errant vehicle. Each end of Type M and C CMB systems, where it is not transitioned to another barrier system should be treated appropriately with a crash cushion.

Transitions

Type M and C CMB can be connected to semi-rigid barrier systems including Type M SBGR. The standard transition and connection details reduce the likelihood of vehicle snagging, pocketing or penetration. Only standard transition and connection details should be used on the provincial highway system.

Both approach and leaving end connections should conform to standard transition design requirements.

Standard designs have been developed to transition from Type M and C CMB to concrete bridge rails.

4.4 Barrier End Terminals and Crash Cushions

All MTO contracts advertised after September 1, 2016 that included installations of new Steel Beam Energy Attenuating Terminals should have specified terminals that met the crash test acceptance requirements of MASH TL-3.

All MTO contracts advertised after December 31, 2016 that included installations of new Type M SBGR with approach end terminals located on horizontal curves with centerline radii less than 190m should have specified Steel Beam Terminals that met the crash test acceptance requirements of MASH TL-3.

All MTO contracts advertised after December 31, 2016 should no longer have specified new installations of Eccentric Loader Terminals (ELT) or Crash-Cushion Attenuating Terminals (C-CAT).

All MTO contracts advertised after May 25, 2009 that included the tender items for permanent and temporary energy attenuators (crash cushions) for installation at ends of permanent or temporary concrete barrier, should have specified energy attenuators that met the crash test acceptance requirements of MASH TL-2 or TL-3, dependent on the posted speed of the facility. NCHRP Report 350 systems may be used in categories where MASH systems are not available.

Errant vehicle impacts with the untreated ends of semi-rigid or rigid barrier systems or fixed objects have a high potential risk of serious injury to vehicle occupants. This is due to high deceleration forces or vehicle instability that would result. Barrier end terminals and crash

cushions are used to reduce the severity of such impacts by attenuating collision energy through gradual vehicle deceleration or through vehicle redirection away from the fixed object.

Barrier end terminals and crash cushions primarily serve to lessen the severity outcome of collisions, rather than prevent them from occurring.

An end terminal is normally used at the end of a barrier system where traffic passes on one side of the barrier and protection from a head-on impact is necessary in one direction only. A crash cushion is normally used to shield the end of a median barrier system, a fixed object located in the median, or an object located within a gore area.

A crash cushion may also be used to shield an object on either side of a roadway, if it is more suitable and/or cost-effective than a barrier system.

Crash cushions are also used in work zones to shield the ends of temporary barrier systems.

End terminals and crash cushions are generally designed to safely stop and/or redirect passenger cars and light-duty trucks. For design impacts, these systems are designed to keep deceleration forces below specified limits, resulting in a lower risk of serious injury to vehicle occupants during impacts the system was designed for.

End terminals and crash cushions do not function in isolation. They are selected and designed as one element of an integrated roadside system that includes consideration of the roadway, shoulder, foreslopes, drainage facilities and the roadside environment. These elements should be designed to function in conjunction with one another to maximize safety benefits.

Design Guidance:

Grading between the travelled way and end terminals or crash cushions should be relatively flat (10H:1V or flatter). The terrain should be free of obstacles that may affect vehicle stability prior to the moment of contact with the end terminal or crash cushion. When the use of curb and gutter adjacent to end terminals or crash cushions is unavoidable, mountable curb should be used to maintain vehicle stability prior to impact.

The performance of end terminals and crash cushions is dependent on correct installation, maintenance, and post-crash repair. Careful attention should be paid during the design stage to system selection and specification, integration with other design elements, as well as orientation and positioning. Grading and anchorage requirements, length of need, and suitability to expected traffic characteristics should also receive proper attention.

All end terminals and crash cushions specified on provincial highway project are proprietary products. These products are available exclusively from the manufacturer or designated distributor for the area. Such products are generally purchased as a complete system, with ongoing logistical support (e.g. installer and repair training, technical assistance and replacement components) available from manufacturer or distributor.

4.4.1 SBGR End Terminals

The following steel beam guide rail end terminals are accepted and specified for use on the provincial highway system:

Steel Beam Energy Attenuating Terminal System (SBEAT):

- MASH MAX-Tension Terminal System
- MASH Sequential Kinking Terminal System
- MASH SoftStop Terminal System
- MASH SPIG Gating End Terminal System

Steel Beam Energy Attenuating Terminal System (SBEAT), Median:

- MASH MAX-Tension Median Terminal System

Steel Beam Terminal (SBT)

- MASH Slotted Rail Terminal System
- MASH Flared Energy Attenuating Terminal System

Crashworthy roadside devices should be installed, maintained, and inspected to ensure their condition reflects the as-tested configuration and adheres to manufacturer's requirements. Failure to comply with the nature in which these systems were tested can result in failure which could lead to serious injury or fatality of vehicle occupants.

Installation, maintenance and inspection of guide rail, end terminals, crash cushions, high tension cable guide rail, and small / intermediate sign support systems should be performed by persons with manufacturer-accredited training in these activities.

4.4.1.1 End Terminal Grading

All of the SBGR end terminals specified by the ministry are classified as “gating” systems, a term which describes their behavior when impacted at an angle near the impact head. A gating end terminal allows a vehicle impacting the nose or side of the system immediately downstream of the nose, to pass through the device. For impacts within the length of need, gating end terminals have redirection characteristics that are compatible with the roadside barrier. Due to the gating performance of these systems, the area behind and beyond all end terminals should be traversable and free of fixed obstacles. This configuration is illustrated in Figure 4-~~22-25~~

Roadside grading should be designed to accommodate the operation of end terminals and crash cushions. Steel Beam Energy Attenuating Terminal (SBEAT) systems for SBGR installations are flared to reduce nuisance impacts and also require special accommodations in roadside grading and drainage facilities. The relatively flat area should extend at least 1.5 m behind the terminal nose in a direction away from the road so errant vehicles impacting the terminal (right shoulder installation) with the left front of the vehicle will not reach a high roll angle prior to impact. Figure 4-~~22-25~~ shows the desirable grading cross-sections for a new SBEAT installation along with flaring of the SBEAT.

Designers have the flexibility to extend the length of guide rail installations to a location where desirable grading requirements for a new SBEAT installation can be better accommodated.

Designers also have the flexibility to provide less than the desirable grading requirements for new end terminal installations when constrained by environmental or property restrictions. This may include reducing the desirable widening behind terminal post #1 and/or increasing the steepness of the slope behind the system. This should be documented in the project file.

Where the roadway is being widened for the installation of and SBEAT, drainage requirements need to be considered and addressed.

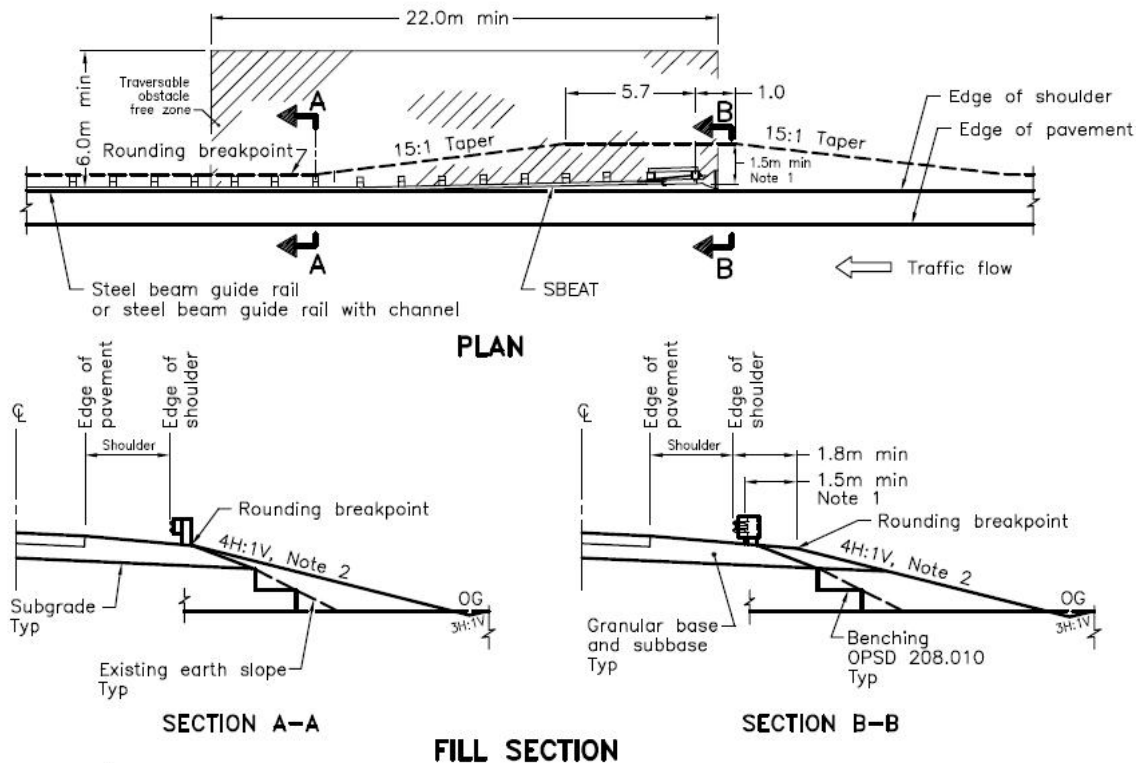

Figure 4-2125: Desirable Grading for SBEAT Installations

See applicable standard for Notes

4.4.1.2 Max Tension Terminal System

The MAX-Tension tangent end terminal is a proprietary gating redirective energy absorbing system that meets the crash test acceptance requirements of MASH TL-3.

The system uses a tension-based design along with an energy absorbing coupler that features cutting tooth design. When impacted head-on, deceleration is controlled by friction developed in the tension cables and by cutting the downstream guide rail panels. When an angled side impact occurs beyond post 4, tension cables help the beams to redirect a motorist away from the obstacle being shielded along the system.

The MAX-Tension terminal uses many standard guide rail components such as steel posts, rails and offset blocks.



Figure 4-~~2226~~: MAX-Tension Terminal System

Photo courtesy of Lindsay Corporation

Manufacturer: Lindsay Corporation – Barrier Systems

Web Site: <http://www.barriersystemsinc.com>

4.4.1.3 SoftStop Terminal System

The SoftStop tangent end terminal is a proprietary gating redirective energy absorbing system that meets the crash test acceptance requirements of MASH TL-3.

The system uses a tension-based design with a front anchor that is designed to allow the rail panels to remain anchored during end-on impacts. When an angled side impact occurs beyond post 3, the system redirects a motorist away from the obstacle being shielded along the system.



Figure 4-~~2327~~: SoftStop Terminal System

Manufacturer: Trinity Highway Products

Web Site: <http://www.highwayguardrail.com>

4.4.1.4 MASH Sequential Kinking Terminal System

The MASH Sequential Kinking Terminal (MSKT) system is a proprietary gating redirective energy absorbing system that meets the crash test acceptance requirements of MASH TL-3.

The MSKT is a compression-based design which is an update to the Sequential Kinking Terminal (SKT) system that met NCHRP Report 350. During head-on impacts, the MSKT head slides over the W-beam guardrail and the rail is sequentially kinked as it moves through the impact head. The kinked guardrail exits the head behind the system away from the roadway and the vehicle

is brought to a controlled stop. This is the same technology used by the SKT. Also similar to the SKT, angled impacts beyond post 3 are redirected along the system by the MSKT.

The MSKT impact head may be used for repairs of existing SKTs. However, use of the MSKT head on an existing SKT installation does not convert the existing SKT into a system that meets MASH. The MSKT also has a ground strut connecting posts 1 and 2 together at ground level, which the SKT does not use.



Figure 4-2428: MSKT Installation
Photo courtesy of Road Systems, Inc.

As with all compression based terminal systems (MSKT, SKT, Eccentric Loader Terminal, Extruder Terminal and CAT), the 20 cm x 20 cm bearing plate at post #1 needs to be correctly positioned with bolt located closer to bottom of plate (eg., centre of bolt is 12.5 cm below top of plate and 7.5 cm above bottom of plate) as shown in Figure 4-~~26~~29. It is acceptable to place a retainer/tie over the bearing plate to prevent rotation. The anchor cable is taut and correctly installed.



Figure 4-~~25~~29: Correct Orientation of Bearing Plate on Compression Based Terminals Photo courtesy of Road Systems, Inc.

Manufacturer: Road Systems Inc.

Web Site: <http://www.roadsystems.com>

4.4.1.5 SPIG Gating End Terminal

The Safety Products Innovations in Guardrail (SPIG) Gating End Terminal (SGET) system is a proprietary gating redirective energy absorbing system that meets the crash test acceptance requirements of MASH TL-3. It was developed by SPIG Industries in Bristol Virginia.

During head-on impacts, the SPIG head engages the vehicle and impacts Post 1 which breaks away. The impact head then slides over the W-beam guiderail and the rail is flattened as it moves through the impact head while Posts 2 through 8 break away at ground level. The flattened guardrail exits the head behind the system away from the roadway and the vehicle is brought to a controlled stop. The system is gating-redirective, angled impacts beyond Post 3 are redirected along the system by the SGET.



Figure 4-2630: SPIG Gating End Terminal Installation

Photo courtesy of SPIG Industries

Manufacturer: SPIG Industries

Website: <https://spigindustry.com/sget>

4.4.1.6 Max Tension Median Terminal

The MAX-Tension Median end terminal is a proprietary gating redirective energy absorbing system that meets the crash test acceptance requirements of MASH TL-3. The system functions similarly to the roadside Max Tension system. The main difference between the two systems is the wider impact head which allows for termination of a double-sided 785 mm high guiderail system.

The system uses a tension-based design along with an energy absorbing coupler that features cutting tooth design. When impacted head-on, deceleration is controlled by friction developed in the tension cables and by cutting the downstream guide rail panels. When an angled side impact occurs beyond post 3, tension cables help the beams to redirect a motorist away from the obstacle being shielded along the system.

The MAX-Tension Median terminal uses many standard guide rail components such as steel posts, rails and offset blocks.



Figure 4-2731: Max Tension Median Terminal Installation

Photo courtesy of Lindsay Corporation

Manufacturer: Lindsay Corporation – Barrier Systems

Web Site: <http://www.barriersystemsinc.com>

4.4.1.7 Median Attenuating Trend Terminal

The Median Attenuating Trend Terminal or MATT is a proprietary gating redirective energy absorbing system that meets the crash test acceptance requirements of MASH TL-3.

The system absorbs energy through a combination of rail shearing and post yielding. When impacted head-on, the rail segment is pushed back and past the blockout. The tabs punched in the rail engage with the blockout assembly and the steel between the tabs is sheared.

Additionally, as a vehicle reaches a post, the upper portion breaks away from the lower portion. When an angled side impact occurs beyond post 2, the system redirects an impacting vehicle away from an obstacle being shielded by the system.



Figure 4-32: Median Attenuating Trend Terminal
Photo courtesy of Trinity Industries

Manufacturer: Trinity Industries

Web Site: <http://www.trinityhighway.com>

4.4.1.78 Slotted Rail Terminal

The Slotted Rail flared end Terminal (SRT) is a proprietary gating non-energy absorbing, end terminal system that meets the crash test acceptance requirements of MASH TL-3.

The system is installed with a 10:1 (5.7°) flare with rail at post #1 offset 1.22 m away from the shoulder.

When an angled side impact occurs beyond post 4, the system redirects a motorist away from the obstacle being shielded along the system.

This system is acceptable for Steel Beam Terminal (SBT) item and is typically specified for use on provincial highway projects where Type M SBGR starts on either the inside or outside edge of a horizontal curve with centerline radii less than 190m.



Figure 4-2833: Slotted Rail Terminal
Photo courtesy of Trinity Highway Products

Manufacturer: Trinity Highway Products

Web Site: <http://www.highwayguardrail.com>

4.4.1.89 MASH Flared Energy Attenuating Terminal

The MASH Flared Energy Attenuating Terminal (MFLEAT) is a proprietary gating energy absorbing, end terminal system that meets the crash test acceptance requirements of MASH TL-3.

The system is installed with a 13:1 (4.3⁰) flare with rail at post #1 offset 0.91 m away from the shoulder. The system may be installed at an offset of 1.22m from the shoulder provided the flare rate of 13:1 is maintained. This requires the start of the flaring to be extended further down the length of the guiderail.

When an angled side impact occurs beyond post 4, the system redirects a motorist away from the obstacle being shielded along the system.

This system is acceptable for Steel Beam Terminal (SBT) item and is typically specified for use on provincial highway projects where Type M SBGR starts on either the inside or outside edge of a horizontal curve with centerline radii less than 190m.



Figure 4-2934: MASH Flared Energy Attenuating Terminal
Picture courtesy of Road Systems Inc

Manufacturer: Road Systems Inc.

Web Site: <http://www.roadsystems.com>

4.4.2 Crash Cushions

Crash cushions are classified into the following categories based on their behavior upon impact:

- Redirective, gating
- Redirective, non-gating; or
- Non-redirective, gating:

A redirective, gating crash cushion allows a vehicle impacting the side of the unit at an angle, near the nose, to pass through the crash cushion. In head-on impacts, a redirective, gating crash cushion should bring the impacting vehicle to a controlled stop. The beginning of length of need of a redirective, gating crash cushion varies, depending on the specific crash cushion employed. For impacts within the length of need (e.g. downstream of the gating nose portion of the crash cushion), a gating, redirective crash cushion has similar redirection characteristics as a standard roadside barrier.

A redirective, non-gating crash cushion is capable of redirecting a vehicle impacting the side of the crash cushion at an angle along the unit's entire length. In head-on impacts, a redirective, non-gating crash cushion should bring the impacting vehicle to a controlled stop. The length of need of a redirective, non-gating crash cushion starts from the nose. For impacts within the length of need, a redirective, non-gating crash cushion has the same redirection characteristics as the adjacent barrier system.

A non-redirective, gating crash cushion cannot redirect vehicles impacting anywhere along its length. In head-on impacts, a non-redirective, gating crash cushion should bring the impacting vehicle to a controlled stop. Vehicles impacting the sides of a non-redirective, gating crash cushion at an angle may either be contained, proceed through the crash cushion or be deflected, depending on their impact angle, impact point, speed, and weight.

4.4.2.1 Summary of Crash Cushions

The crash cushions (energy attenuators) currently accepted and specified for installation as permanent systems on provincial highway projects are listed in Table 4-3.

Energy Attenuator	NCHRP Report 350 or AASHTO MASH Test Level		Permanent Installation					
	TL-2	TL-3	Narrow	Wide	Extra Wide	Super Wide	High Exposure	Single- Sided
TAU-M System	Yes	Yes	Yes	No	No	No	No	No
TAU-II Wide System	Yes	Yes	No	Yes	No	No	No	No
TAU-II Extra Wide System	Yes	Yes	No	No	Yes	No	No	No
QuadGuard M10 System	Yes	Yes	Yes	No	No	No	No	No
QuadGuard M10 Wide System (1)	Yes No	Yes	No	Yes	No	No	No	No
<u>QuadGuard Wide System</u>	<u>Yes</u>	<u>Yes</u>	<u>No</u>	<u>Yes</u>	<u>No</u>	<u>No</u>	<u>No</u>	<u>No</u>
QuadGuard Extra Wide System	Yes	Yes	No	No	Yes	No	No	No
QuadGuard Super Wide System	No	Yes	No	No	No	Yes	No	No
<u>Delta System</u>	<u>Yes</u>	<u>Yes</u>	<u>Yes</u>	<u>No</u>	<u>No</u>	<u>No</u>	<u>No</u>	<u>No</u>
QuadTrend	No	Yes	No	No	No	No	No	Yes
BB-BEAT	No	Yes	No	No	No	No	No	Yes
Smart System	Yes	Yes	Yes	No	No	No	Yes	No
<u>SMA Hercules</u>	<u>No</u>	<u>Yes</u>	<u>Yes</u>	<u>No</u>	<u>No</u>	<u>No</u>	<u>No</u>	<u>No</u>

1. The QuadGuard M10 Wide shall be used for Permanent Unidirectional configurations requiring a TL-3 system. For all other configurations, including Temporary and Bidirectional as well as TL-2 applications, the QuadGuard Wide system shall be used.

Table 4-3: Permanent Energy Attenuators

Test Level and Posted Speed

All of the crash cushions accepted for use on the provincial highway system meet the crash test acceptance requirements of NCHRP Report 350 TL-2 or TL-3, and some have also recently been crash tested to meet the crash test acceptance requirements of MASH TL-3. For each crash cushion installation, the appropriate test level should be determined based on the posted speed of the roadway. TL-2 configurations are specified for low-speed installations with posted speeds of less than 70 km/h. TL-3 configurations are specified for high-speed installations with posted speeds of 70 km/h and greater.

Redirective, Gating Systems

The systems listed under the Single Sided column in Table 4-3 are redirective, gating Crash Cushions and are specified for permanent installations only. These crash cushions should be used in locations where vehicles will impact the system from one side only, typically on roadside shoulders. A traversable area free of fixed obstacles is required behind and beyond the system as shown in Figure 4-31-35.

Desirable grading, as shown in Figure 4-31-35 should be used at all installations of redirective, gating crash cushions.

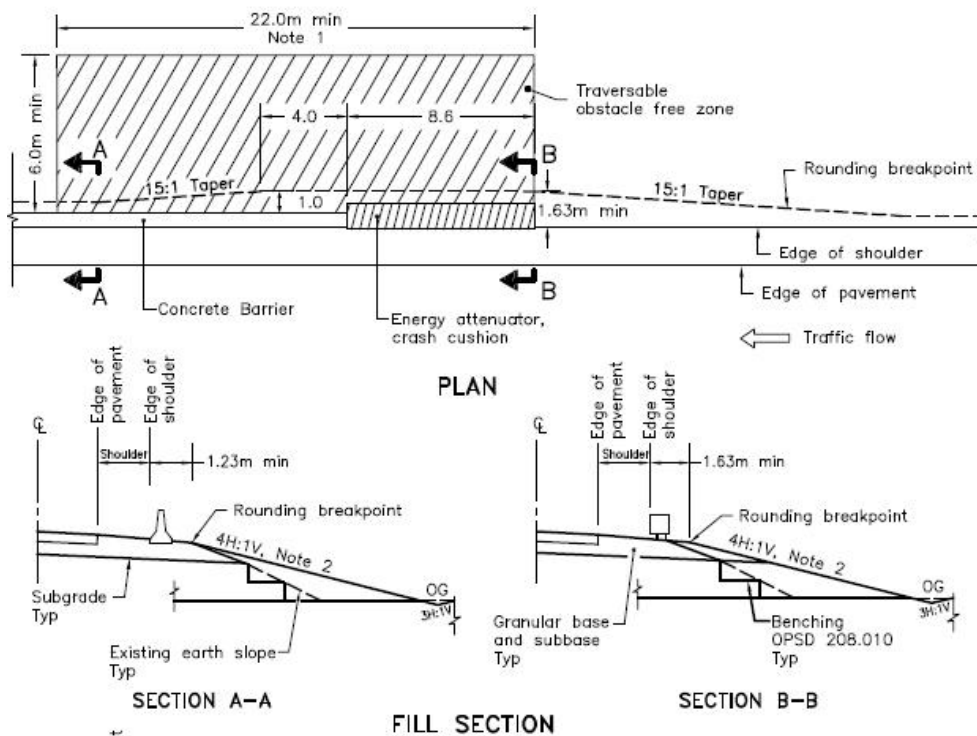

Figure 4-3035: Desirable Grading for Single Sided Energy Attenuating Terminals

Redirective, gating crash cushions should not be installed in a location where backside impacts are possible (e.g., in gore areas), or in a narrow medians where backside, opposite direction impacts are possible.

Redirective, gating systems are currently only available in a TL-3 configuration.

Redirective, Non-Gating Systems

The systems listed under the Narrow, Wide, Extra Wide, Super Wide and High Exposure columns in Table 4-3 are redirective, non-gating crash cushions. Following a design impact, these systems can typically be repaired. However, major component replacement may be required in order to make the entire system crashworthy again.

The QuadGuard, QuadGuard M-10, Tau-II, TAU-M and Smart crash cushions are specified for permanent and temporary use.

The Smart system listed under the High Exposure column in Table 4-3 is specified for locations where there is a high risk of impact such as in the gore of a core / collector transfer. The Smart is desirable in locations where the system will be installed close to the traveled way, where site access is limited, and/or where lane closures are costly and disruptive. The Smart system has been proven to be the least expensive of all crash cushions specified by MTO to repair after design impacts, typically just requiring replacement of two shear bolts after the system is pulled back.

All of the accepted and specified redirective, non-gating systems can be installed in unidirectional and bidirectional configurations.

Redirective, non-gating systems are available in TL-2 and TL-3 configurations.

Terrain and Foundation Requirements

Crash Cushions are typically tested on paved, flat and level terrain. It is desirable to install crash cushions on relatively flat terrain, and the traversable area between the travelled portion of the roadway and the device should be free of obstacles and irregularities. Approaches to the crash cushion should be 10H:1V or flatter. A traversable area, free of significant fixed objects, should be provided adjacent and beyond the crash cushion.

Crash cushions should not be placed on surfaces with a crossfall greater than 6%.

All permanent crash cushions should be installed on a new reinforced concrete pad, with the exception of the Box Beam Bursting Energy Absorbing Terminal, which is installed on driven steel posts into compacted granular base. If an existing concrete surface or pad can be used to support the crash cushion, its surface must be in good condition in order to accommodate installation of anchors for the system.

Temporary crash cushions may be anchored to existing concrete surfaces, asphalt over compacted granular, or to asphalt over concrete. The existing surface must be in good condition in order to provide a smooth operating surface. The following dimensions represent the minimum foundation requirements for temporary crash cushion installation:

- Existing Concrete Surface:
 - Minimum 200 mm deep concrete with 28 MPa minimum compressive strength
- Asphalt over Compacted Granular:
 - Minimum 150 mm asphalt over a minimum 150 mm compacted granular
 - The asphalt must extend a minimum of 500 mm beyond the anchor bolts
- Asphalt over Concrete
 - Minimum 75 mm asphalt over a minimum 75 mm concrete with 28 MPa minimum compressive strength

Where temporary crash cushions are required to be placed on the inside of horizontal curves, the geometry of the proposed location should be checked to ensure that the crash cushion, and downstream barriers placed tangent to the crash cushion, will not result in excessive encroachment of the crash cushion into the shoulder or any encroachment into the travelled lane when installed. If such a conflict is identified, alternative locations should be considered which may require lengthening of a temporary construction barrier run or an alternative staging arrangement.

Curb and Gutter

Crash cushions should not be installed within close proximity to barrier curb and gutter. Where curb and gutter is required, mountable curb should be used starting approximately 15 m in front of the crash cushion and as far back as the system's backup.

Delineation of Crash Cushions

A crash cushion typically does not reduce the frequency of impacts. The intent of a crash cushion is to lessen the severity of impacts when they do occur. However, delineation of the crash cushion may provide some reduction in the frequency of collisions with crash cushions.

Each permanent and temporary crash cushion installation should include appropriate delineation. For permanent installations, delineation should include a standard object marker and snow plow marker. For temporary installations, delineation should include a standard object marker and snow plow marker as well as flexible delineator posts when the crash cushion is located in a gore area or in a location where the shoulders are less than 2.0 m in width.

When installed on a paved surface, the signs should be mounted on a surface mounted flexible post. When installed on a granular surface, the signs should be mounted on a steel U channel post.

4.4.2.2 Box Beam Bursting Energy Absorbing Terminal

The Box Beam Bursting Energy Absorbing Terminal (BB-BEAT) System is a proprietary redirective, gating, single sided crash cushion that meets the crash test acceptance requirements of NCHRP Report 350 TL-3.

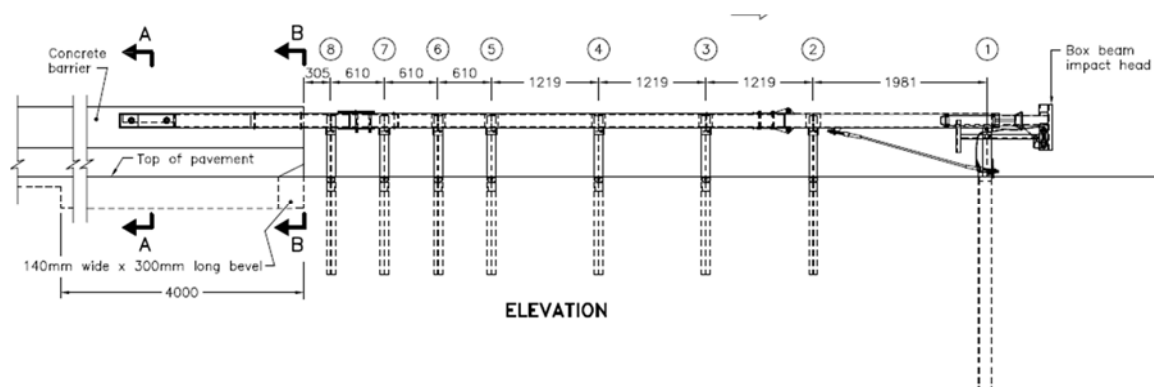

Figure 4-3136: Box Beam Bursting Energy Absorbing Terminal

For head on impacts, the system absorbs energy in three stages. The impact head will engage the front of the vehicle and will be pushed forward along the stage one box beam rail element. The impact head will then contact the post breaker beam and break off the first steel breakaway post, releasing the cable anchorage. The tapered mandrel will split the box beam. If the vehicle has sufficient energy, it will continue into the stage two box beam rail element in the same manner, progressively splitting the box beam as the vehicle moves along. The system is designed to dissipate the energy from a 2000 kg pick up truck within the first two stages. However, additional capacity is provided by the third stage box beam rail element.

When the BB-BEAT is hit at an angle between the impact head and the third post, the impacting vehicle will gate through the system in a controlled manner and travel in behind the system before coming to rest.

The cable anchorage system provides the necessary tensile strength in the box beam rail to resist and redirect impacts downstream of the third post.

The BB-BEAT is typically used to shield the ends of concrete roadside barriers. It should only be used in locations where vehicles will impact the system from one side only. The BB-BEAT is acceptable and specified for permanent use only as a single sided crash cushion for permanent installations.

Manufacturer: Road Systems, Inc.

Web Site: <http://www.roadsystems.com/>

4.4.2.3 QuadTrend 350 End Treatment System

The QuadTrend is a proprietary redirective, gating, crash cushion that meets the crash test acceptance requirements of NCHRP Report 350 TL-3.



Figure 4-3237: QuadTrend Terminal

The system is 5.87 m in length. The post slip bases are anchored to a reinforced concrete pad and the rear end of the system is anchored to the concrete barrier wall using an offset transition panel. The front end of the redirecting cable is anchored to the concrete foundation in front of the first post. The rear end of the redirecting cable is routed through the first post and then extends at an angle of 25 degrees away from the system to an anchor block located 3.0 m behind the system on the roadside slope.

For head on impacts, the system simultaneously collapses and moves laterally along the redirecting cable to redirect an impacting vehicle away from the end of the concrete barrier. As

the system collapses, the Quad-Beam fender panels telescope rearward and the posts shear at the slip bases. The sand-filled containers help dissipate collision energy. The Quad-Beam fender panels redirect the vehicle away from the hazard during side and reverse direction impacts. The QuadTrend System is typically used to shield the ends of concrete roadside barriers.

The QuadTrend should be used in locations where vehicles will impact the system from one side only. This will typically include roadside shoulders where there is sufficient space to provide an area behind and beyond the system that is traversable and free of fixed obstacles for a width of 6.0 m and a length of 22.0 m. The QuadTrend System is acceptable and specified for permanent use only as a single sided crash cushion for permanent installations.

Manufacturer: Energy Absorption Systems, Inc.

Web Site: <http://www.energyabsorption.com>

4.4.2.4 QuadGuard and QuadGuard M10 Systems

The QuadGuard System is a proprietary redirective, non-gating, crash cushion that meets the crash test acceptance requirements of NCHRP Report 350 TL-2 and TL-3. The QuadGuard M10 version of the system meets the requirements of MASH TL-2 and TL-3.

The system consists of a series of energy-absorbing cartridges supported by a framework of steel diaphragms and Quad-Beam fender panels. The self-supporting nose consists of a formed plastic wrap and an energy-absorbing cartridge. The system uses a centre monorail base that resists lateral movement during side impacts and a tension strut backup structure that anchors the system and resists movement during head-on impacts. The monorail base and tension strut backup are anchored to the foundation.



Figure 4-~~3338~~: QuadGuard M10

Photo courtesy of Energy Absorption Systems, Inc.

For head on impacts, the cartridges absorb the impact energy while the fender panels telescope rearward on the diaphragms that slide along the monorail base as the system collapses. The tension strut backup provides anchorage for the system.

The QuadGuard System is a crash cushion used to shield the ends of barrier systems or fixed objects that may be impacted from both sides in a unidirectional or bidirectional installation. The QuadGuard System is acceptable and specified for permanent and temporary use.

The narrow system is typically used to shield the ends of concrete barrier. The wide and extra wide systems are typically used to shield the ends of two runs of concrete barrier that meet at gore or median locations or for shielding fixed objects such as bridge piers.

Currently the Quad Guard M10 is only available as a narrow system. The QuadGuard system shall continue to be used for wide, extra wide and super wide applications. See Table 4-3 for details.

Manufacturer: Energy Absorption Systems, Inc.

Web Site: <http://www.energyabsorption.com/index.asp>

4.4.2.5 SMART Cushion

The Smart System is a proprietary redirective, non-gating, crash cushion that meets the crash test acceptance requirements of NCHRP Report 350 TL-2 and TL-3, and was subsequently crash tested without any modifications to MASH TL-3.



Figure 4-~~34~~39: SMART Unidirectional Crash Cushion

For head on impacts, the system telescopes rearward as the side panels slide one over the next. The system is speed dependent and stops small vehicles by the hydraulic ram automatically regulating the stopping force exerted on the vehicle. Therefore, small vehicles are stopped at a slower rate than larger vehicles. This minimizes the deceleration forces on the vehicle occupants.

The Smart Cushion is a crash cushion used to shield the ends of barrier systems or fixed objects that may be impacted from both sides in a unidirectional or bidirectional installation. The Smart Cushion is acceptable for permanent and temporary use.

The Smart Cushion is categorized as a low maintenance system that is suitable to locations where there is high exposure and risk of impact such as in the gore of a core/collector transfers. Following most head on impacts, a trained repair crew can reset an impacted Smart Cushion in 30 to 60 minutes. In addition, it has been documented that more than 80% of Smart Cushion repairs required replacement of only the two shear bolts. In side impacts, the fender panels often receive little to no damage. As a result, repair crew exposure to traffic and motorist inconvenience is typically minimized as well as repair cost.

Manufacturer: SCI Products, Inc.

Web Site: <http://workareaprotection.com/attenuators/>

4.4.2.6 TAU-II and TAU-M Systems

The TAU-II System is a proprietary redirective, non-gating, crash cushion that meets the crash test acceptance requirements of NCHRP Report 350 TL-2 and TL-3. The TAU-M version meets the crash test acceptance requirements of MASH TL-2 and TL-3.

The system consists of a series of energy absorbing cartridges supported by a framework of steel diaphragms and telescoping three beam side panels.

The nose consists of a formed plastic wrap. The system uses two cables to resist lateral movement during side impacts and a compact backstop structure that anchors the cables and resists movement during head-on impacts.

The cables are attached to the compact backstop at the rear of the system and anchored to the foundation at the front of the system. The compact backstop is anchored to the foundation. The cables pass through the diaphragms, which are not anchored to the foundation.



Figure 4-3540: TAU-M narrow system

For head on impacts, the cartridges absorb the impact energy while the fender panels telescope rearward on the diaphragms that slide along the cables as the system compresses. The compact backstop(s) and front cable anchor(s) are bolted to the reinforced concrete pad according to manufacturer guidelines. The fender panels, diaphragms, and cables redirect vehicles during side and reverse direction impacts.

The TAU-M system is currently only available for narrow installations. For wide and extra wide applications, the TAU-II system shall continue to be used. See Table 4-3 for additional information.

Manufacturer: Barrier Systems Inc.

Web site: <http://www.barriersystemsinc.com/>

4.4.2.7 SMA Hercules

The SMA Hercules system is a proprietary redirective, non-gating, crash cushion that meets the crash test acceptance requirements of MASH TL-3.

The system consists of a series of all-steel collapsible beams, split into ten bays which slide on a steel base rail which is in turn fastened to a steel base plate. A frontal sliding trolley sits at the upstream end of the system and functions as the nose. The base and rail as well as the 4-beam side panels resist lateral movement during side impacts and a backstop anchors the system and resists movement during head-on impacts. The steel base and backstop are anchored to the foundation.



Figure 4-41: SMA Hercules

For head on impacts, the frontal sliding trolley is pushed along the rail into the collapsible beams which absorb the impact energy as the system collapses. The supports which connect the beams to the base collapse, also dissipating impact energy. The backstop provides anchorage for the system.

The SMA Hercules is a crash cushion used to shield the ends of barrier systems or fixed objects that may be impacted from both sides in a unidirectional or bidirectional installation. The SMA Hercules is acceptable and specified for permanent and temporary use.

Currently the SMA Hercules is only available as a narrow system, and only in a TL-3 configuration although it is appropriate for low-speed installations as well.

Manufacturer: Safety Modular Absorber
Web site: <http://www.smaroadsafety.com>

4.4.2.8 Delta Crash Cushion

The Delta system is a proprietary redirective, non-gating, crash cushion that meets the crash test acceptance requirements of MASH TL-3.

The system consists of a series of three beam fender panels supported by a framework of steel diaphragms. The nose piece is attached to the front of the system using four bolts. The dual rail base resists lateral impacts. The base of the system is anchored to the foundation.



Figure 4-42: Delta Crash Cushion

For head on impacts, a series of shear bolts tears through pre-punched cut-outs in the sides of the three beam panels, dissipating the impact energy.

The Delta system is a crash cushion used to shield the ends of barrier systems or fixed objects that may be impacted from both sides in a unidirectional or bidirectional installation. The Delta system is acceptable and specified for permanent and temporary use.

Currently the Delta is only available as a narrow system, and only in a TL-3 configuration although it is appropriate for low speed installations as well.

Manufacturer: Traffix Devices

Website: <https://www.traffixdevices.com/products/attenuators/delta>

4.4.3 Barrier System Transitions and Connections

Transitions between different barrier systems are designed to withstand vehicle impacts in the vicinity of the transition between barrier systems of differing rigidity, shape, mounting height, and performance characteristics. This is typically accomplished in a gradual manner because abrupt changes in barrier characteristics such as rigidity or shape could result in a vehicle pocketing or snagging in the vicinity of the transition.

Standard transition designs are available for use on Provincial Highways. Transitions are designed for either one-way or two-way traffic. Care must be taken to ensure that the appropriate standard transition is selected.

4.4.4 Existing In-Service Systems

End terminal and crash cushion design has evolved over the past 40 years along with crash test acceptance criteria. Road authorities, including the ministry, are continually updating and/or implementing standard designs for new hardware. As such, the existing in-service road safety hardware systems represent a broad range of performance characteristics, reflecting the standards-of-the-day when each was installed. While some systems may not meet the current testing procedure, existing in-service systems should still continue to perform on the provincial highway system and may remain in-service until the end of their service lives. An exception to this is for systems that were crash tested according to procedures that predate NCHRP Report 350, such as NCHRP Report 230 and its predecessors. Such systems, though now rare on the provincial highway network, are approximately 30 years old at a minimum and may have deteriorated plastic, steel and anchoring components and should be replaced with currently specified system on all capital projects.

4.5 Poles and Sign Support Systems

Since 2011, all new permanent small sign support systems installed on capital construction contracts on high speed provincial highways should have been breakaway and met the crash test acceptance requirements of NCHRP Report 350 TL-3 unless located behind an appropriate length of existing barrier offset appropriately to accommodate barrier working width. When signs are located behind an appropriate length of barrier, or for low-speed urban installations are located behind barrier curb, both breakaway or non-breakaway small sign support systems are acceptable.

Since March 2, 2017, all new permanent intermediate sign support systems installed on capital construction contracts on high speed provincial highways should have been breakaway and met the crash test acceptance requirements of NCHRP Report 350 TL-3 unless located behind an appropriate length of existing barrier offset appropriately to accommodate barrier working width.

Since the late 1980s, all large sign assemblies consisting of extruded aluminum sign panels generally 2.4 m and wider with total sign areas ranging from 2.9 m² to 23.8 m² installed on capital construction contracts on provincial highways should have been designed and installed according to the latest edition of the Ontario Traffic Manual (OTM) Book 3. OTM Book 3 provides standards and guidelines for the design of large aluminum extruded signs on wood column and steel column breakaway and non-breakaway sign support structures for various sizes of sign assemblies on various slopes. OTM Book 3 provides standard drawings for each sign support structure which require the design and completion of fill-in tables and dimensions, and shall bear the seal, date and signature of a Professional Engineer. These installations should be breakaway unless being installed behind an appropriate length of existing barrier systems offset appropriately to accommodate barrier working width. For additional details for design and installation of large sign support systems, refer to the latest edition of OTM Book 3.

New barrier systems should not be installed or extended on provincial highway projects for the sole purpose of protecting new or relocated large sign support assemblies when design of breakaway sign support systems are practical and/or sign could be located elsewhere behind an

appropriate length of existing barrier offset appropriately to accommodate barrier working width.

Large overhead signs and cantilever signs on high speed highways should be located behind an appropriate length of existing barrier system offset appropriately to accommodate barrier working width. Overhead and cantilever signs mounted on a crashworthy median or roadside barrier may be shielded with a redirective, non-gating crash cushion with an appropriate width and transition detail. These signs should ~~be~~ designed according to the latest edition of the Sign Support Manual.

Figure 4-~~37~~43 shows the three permanent ground mounted sign support system types listing acceptable sign materials for each system against sign assembly area ranges for each system.

Many breakaway sign support systems are currently being crash tested according to MASH. MTO standards will be updated as MASH-compliant systems are accepted for use on provincial highways.

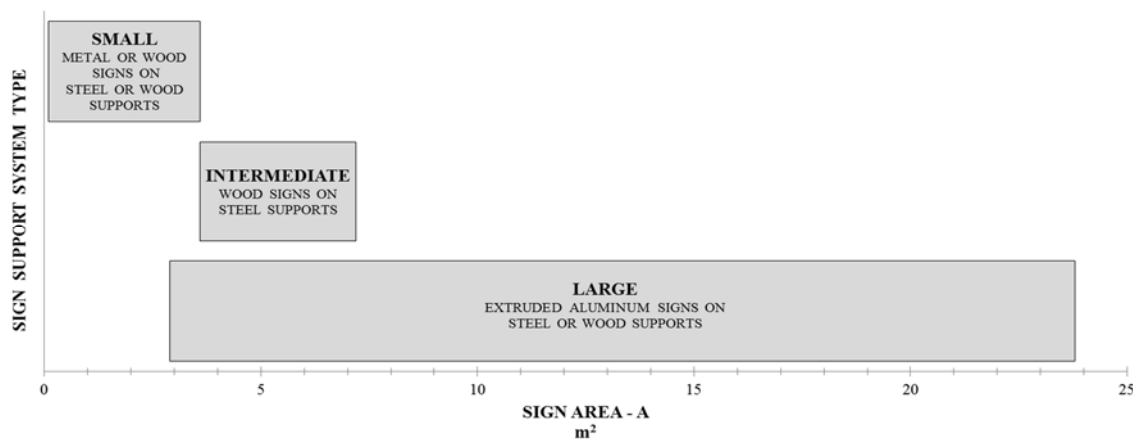

Figure 4-~~36~~43: Sign Support System Types and Sign Areas

4.5.1 Small Sign Support Systems

Although small signs are not always perceived as particularly hazardous, small signs can cause significant damage to impacting vehicles. Small and intermediate breakaway sign support system standards were developed for various sign sizes typically used on provincial highways. Each standard sign support system met the crash test acceptance requirements of NCHRP Report 350 Test Level 3 and designed for wind speeds of 110 km/h (70 mph), and wind load/pressure requirements for a ten-year return period in Ontario according to the Canadian Highway Bridge Design Code.

NCHRP Report 350 requires the sign support system to fail in a predictable manner when impacted head-on by a small vehicle at 35 km/h and at 100 km/h, and by a pick-up truck at 100 km/h. For acceptance, the crash tested vehicle needs to remain upright during and after the impact with minimal deformation or intrusion into the passenger compartment.

In general, the bottom of the sign needs to be mounted at a minimum height of 2.1m above the ground (measured vertically at each post) to allow errant vehicles to pass under the sign during an impact. As the average passenger vehicle is less than 2.1 m wide, when two or more posts are required for larger sign assemblies, the clearance between them should be 2.1 m or greater to minimize the probability of an errant vehicle of impacting two posts at same time. Support system posts may be located closer together than 2.1 m when they have been crash tested in that configuration as specified in the applicable standards.

Wooden sign support system posts of specified species and grade measuring 89 mm x 89 mm are designed to fracture near ground level during a passenger vehicle impact. Larger wooden posts need to be drilled perpendicular to the roadway at a height of 75 mm and 375 mm above the ground to weaken them in shear to ensure they fracture near ground level while maintaining moment capacity to resist wind loads. Figure 4-~~38~~44 shows proper orientation of drilled holes that are specified in the applicable standards for small sign support systems with wooden posts.

For wood support systems, 89 mm x 89 mm (nominal 4" x 4") and drilled 89 mm x 140 mm (nominal 6" x 6") direct buried non-proprietary pressure treated wood post systems have been successfully crash tested in single and double post configurations. The posts are direct buried a minimum of 920mm or 1200mm into the ground, dependent on size and configuration. For these size posts in double post configurations, they are set no more than 2.1 m apart when measured from outside face of each post as shown in Figure 4-~~38~~44. For larger drilled 140 mm x 140 mm or drilled 140 mm x 189 mm posts in double post configurations, the horizontal clearance between the posts is minimum 2.1 m (measured inside face to inside face of each post).

Steel sign support system posts are also designed to fracture near ground level during a passenger vehicle impact. The Nucor Rib-Bak high strength steel post uses a proprietary Lap-Splice and bolts to connect their upper sign post and lower stub post at ground level, with the top of lower stub post set no higher than 100 mm above ground. For double or triple post configurations, they are set no more than 2.1 m apart when measured from outside face of each post as shown in Figure 4-~~39~~45.

The Sqr-Lok perforated square tube small sign support system uses a 57 mm x 57 mm x 1065mm long lower anchor steel post with top set no higher than 100mm above ground. A 63

mm x 63 mm x 450 mm long sleeve is placed over the stub post with top also set no higher than 100 mm above ground. The 52 mm x 52 mm upper post is inserted to a depth of 200 mm inside of the lower anchor posts and sleeve, and then bolted together with the proprietary corner bolt. For double post configurations they are set no more than 2.1 m apart when measured from outside face of each post as shown in Figure 4-~~39~~45.

All steel support systems are pre-punched with 11mm diameter holes at 50mm centres for mounting of the signs. These holes can also be used to jack out existing lower posts during repairs or relocations.

Design Guidance:

Small sign assemblies consist of one or more signs and tabs mounted on a sign support system with specified sign hardware having a total sign or sign board area not greater than 3.6m². These signs may be metal or plywood, and installers are given the option to select the appropriate metal or wooden breakaway sign support system for each small sign assembly based on the dimensions and area of the sign assembly. The system may consist of a single, double, or triple post configuration.

On low speed urban roadways with barrier type curb and posted speeds less than 70 km/h, small signs of up to 90 cm wide by 90 cm high and total sign area including tabs not greater than 0.56m² may continue to be installed on non-breakaway U-flange post system. Breakaway systems may also be installed on low speed urban roadways.

The ministry specifies different types of sign support systems based on the type of sign material, sign dimensions, and total area of the sign including any tabs. Breakaway sign support systems should be used for all new sign installations on high speed and low speed roadways within provincial highway right-of-ways unless located behind an appropriate length of existing barrier. New barriers should not be installed or extended for the sole purpose of protecting a new sign assembly on non-breakaway sign supports.

In general all sign installations are intended for installation on traversable roadsides with sideslopes 3H:1V or flatter. Posts should be offset more than 1.5m from bottom of drainage ditches, and when installed behind barrier should be offset beyond the working width of the barrier system. Sign installations should not be installed within the 22m x 6m obstacle clear area beyond guide rail terminal systems.

Sign installations are intended for installation in competent soils of uniform composition. Site foundation conditions requiring a modification to the design or use of another sign support system include:

- Rock cut
- Rock fills
- Soil is exceptionally soft or loose.

Small signs can measure up to 2.4m wide and up to 1.5m high, with a maximum area up to 3.6 m². For durability, different combinations and sizes of breakaway pressure treated wooden and hot dipped galvanized steel sign support system standards have been developed for various sign sizes typically used on provincial highways. Installers have the option to select the appropriate wooden and/or steel sign support system standard for each sign installation dependent upon sign dimensions and sign area.

General details and dimensions for Permanent Ground Mounted Small Sign Support Systems with single and double wooden post configurations or with single, double or triple steel post configurations can be found in the applicable standards active in MTO's Contract Preparation System.

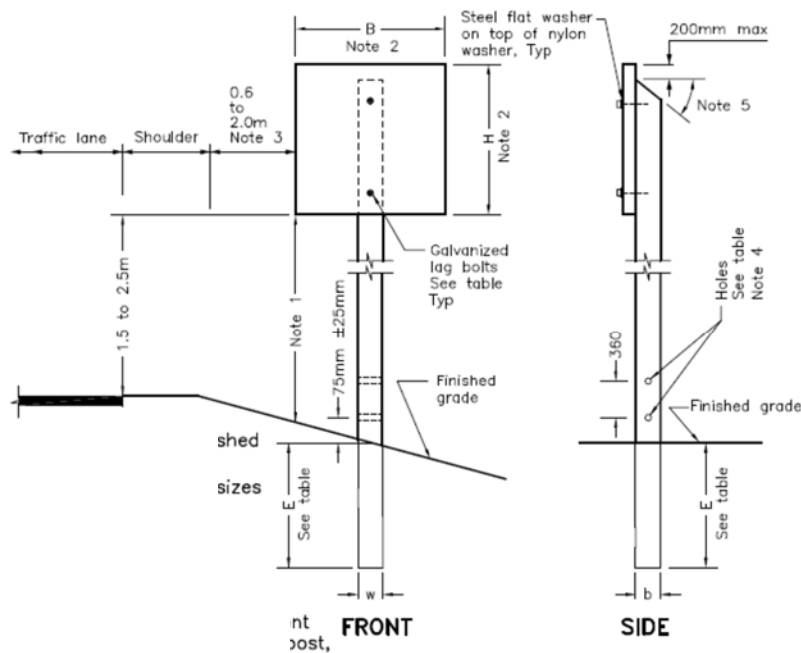

Figure 4-3744: Small Breakaway Single Post System with 89 mm x 140 mm Drilled Wooden Post.

See applicable standards for other post configurations and note references

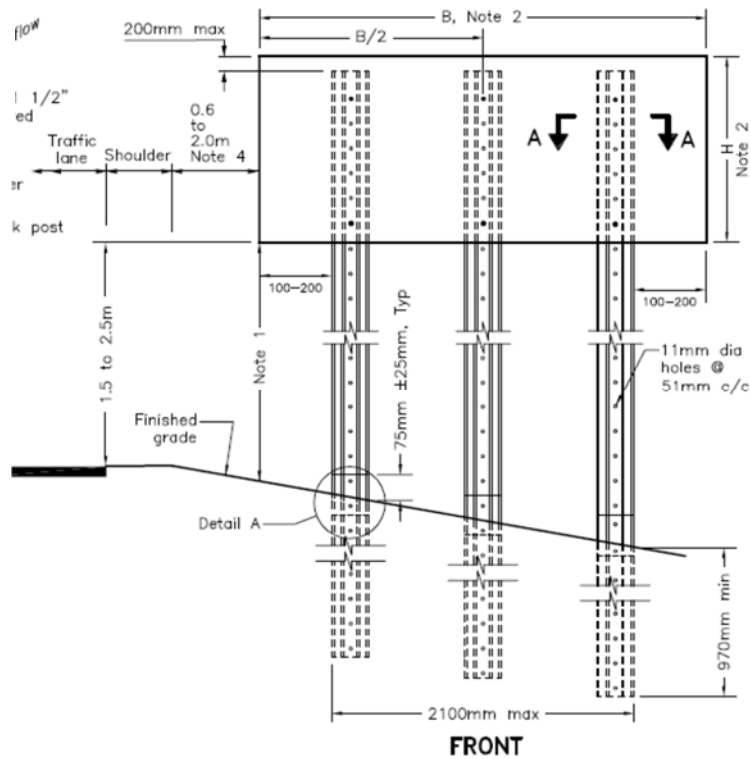

Figure 4-3845: Small Breakaway Triple Post System with Rib-Bak steel posts
See applicable standards for other post configurations and note references.

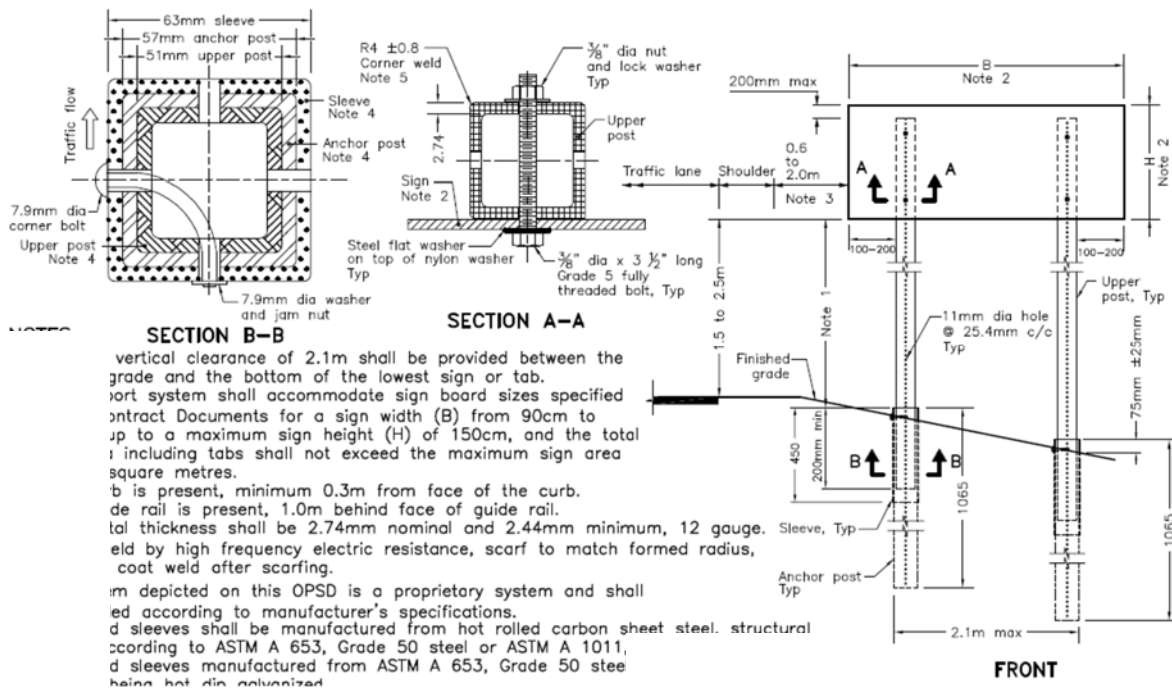

Figure 4-3946: Small Breakaway Double Post System with Sqr-Loc steel posts
See applicable standards for other post configurations and note references.

4.5.2 Intermediate Sign Support Systems

Intermediate sign assemblies consist of one or more signs and tabs mounted on a sign support system with specified sign hardware having a width not greater than 2.4 m, a height not greater than 3.0 m, and a total sign or sign board area not greater than 7.2 m². These plywood signs are installed on the two-post steel breakaway Slip-Safe Supreme system from Nucor Steel Marion, Inc. and do not require concrete footings. The Slip-Safe Supreme system can be installed and repaired quickly, easily and cost effectively as design and placement of concrete footings are not required.

The Slip-Safe Supreme™ is a propriety system developed by Nucor Marion Steel, Inc. This system meets the crash test acceptance requirements of NCHRP Report 350, Test Level 3. This is an alternative option for a multi-panel (in height) plywood signs of up to 3.0 m high and up to 2.4 m wide with a maximum area of 7.2 m². It is acceptable to install small 2.4 m wide wood sign assemblies with areas less than 3.6 m² on intermediate sign support systems when specified. At this time, aluminum extruded signs shall not be installed on the Slip-Safe Supreme system.

The Slip-Safe Supreme system provides a solution for taller plywood signs of up to 3.0 m high and up to 2.4 m wide with a maximum area of 7.2 m². While 2.4 m wide small signs with heights less than 1.5 m and areas less than 3.6m² may be installed on intermediate sign support system, it is generally more economical to install small signs on a small sign support system.

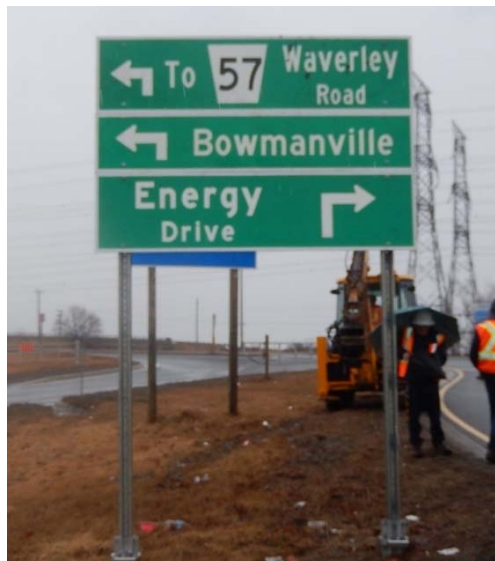

Figure 4-4047: SlipSafe Supreme Intermediate Sign Support System Installation

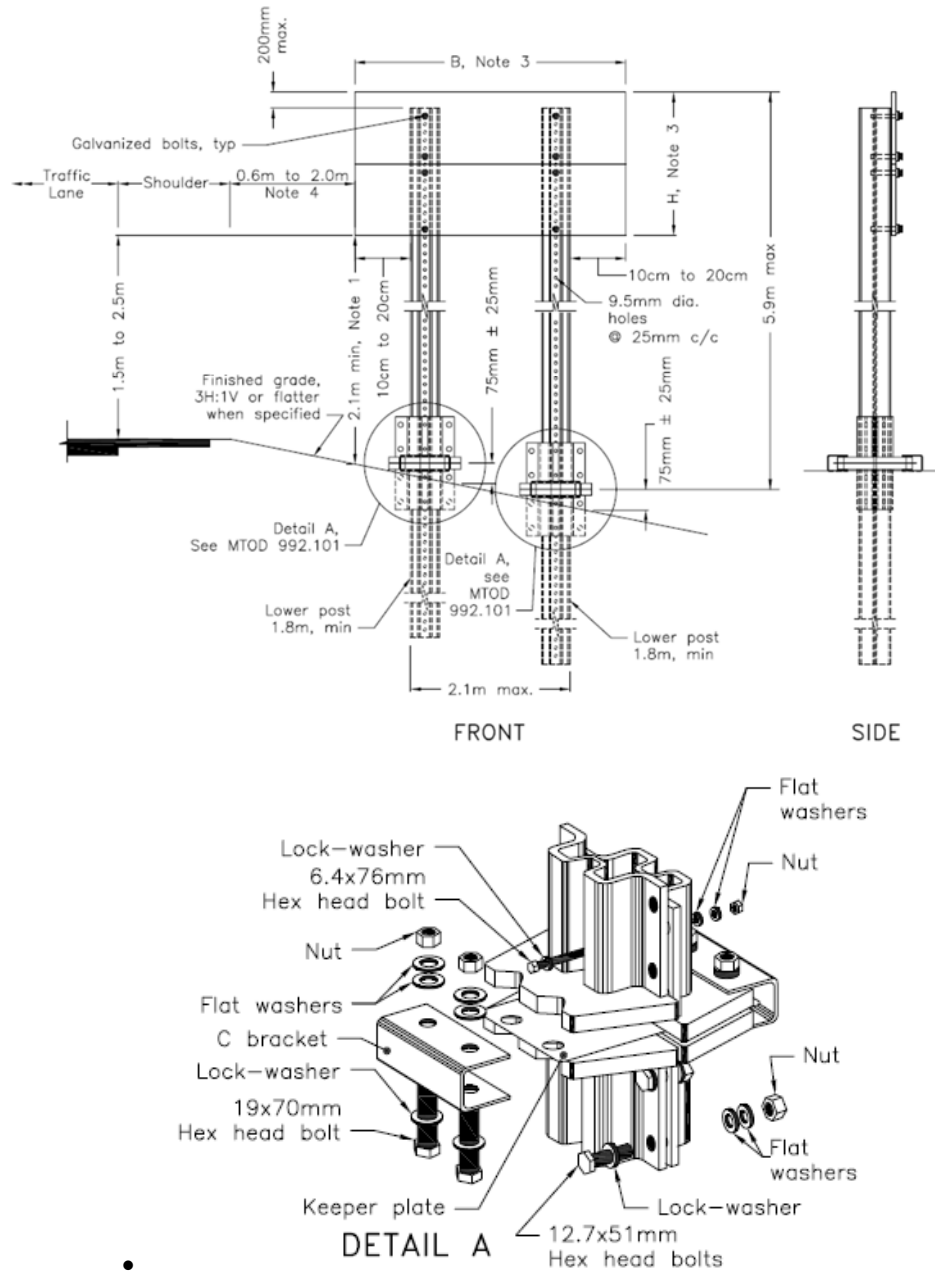

Figure 4-4148: Breakaway Component Details

See applicable standard for other details and note references

4.5.3 Sign Supports on Concrete Median Barrier

The sliding base and chute median sign support is a non-proprietary system developed by Texas Transportation Institution for the Texas Department of Transportation. This system meets the crash test acceptance requirements of MASH Test Level 3. The system consists of a slide assembly which is anchored to the top of the concrete barrier. A collar is placed in the slide assembly which supports a pipe to which the sign board is attached. When impacted by a vehicle from either direction the collar and sign support assembly slides towards the end of the chute where it is stopped by the anchors. The sign support deforms but does not break away and allows for safe containment and redirection of the vehicle.

This design may be used for signs between 60 and 90 cm wide by 150 cm high and not exceeding 1.35 m² in total area. The sliding chute base requires a minimum barrier top width of 200 mm. There is not currently any crash tested designs available for barriers with less than 200 mm top width however a non-tested wooden post with steel plate system is available for use on flared concrete median barriers with a minimum top width of 1.0 m.



Figure 4-4249: Sliding Base and Chute Median Sign Support System Installation

4.6 Ramp Closure Gates

Since about 2009, most new ramp closure gates installed on provincial highway capital construction contracts should have been breakaway when stored in the ramp open position (gate parallel to traffic). The breakaway ramp closure gate implemented by MTO is considered equivalent to the South Dakota DOT gate that was developed and crash tested by MwRSF in 1995 to meet the crash test acceptance requirements of NCHRP Report 350 TL-3. The gates are manufactured from 50 mm x 50 mm square aluminium tubing and are available in standard 9 m and 12 m lengths. Proprietary breakaway double neck Transpo Pole-Safe couplers are used to attach the aluminium gate to the concrete footing. Gates should be installed adjacent to the right shoulder on the ramp as specified on the MTO standards. Figure 4-44-50 shows the standard installation for a single lane 9 m entrance ramp from an arterial road to a freeway. Standard sign layouts are available for attachment of required signs to the gate and support post.

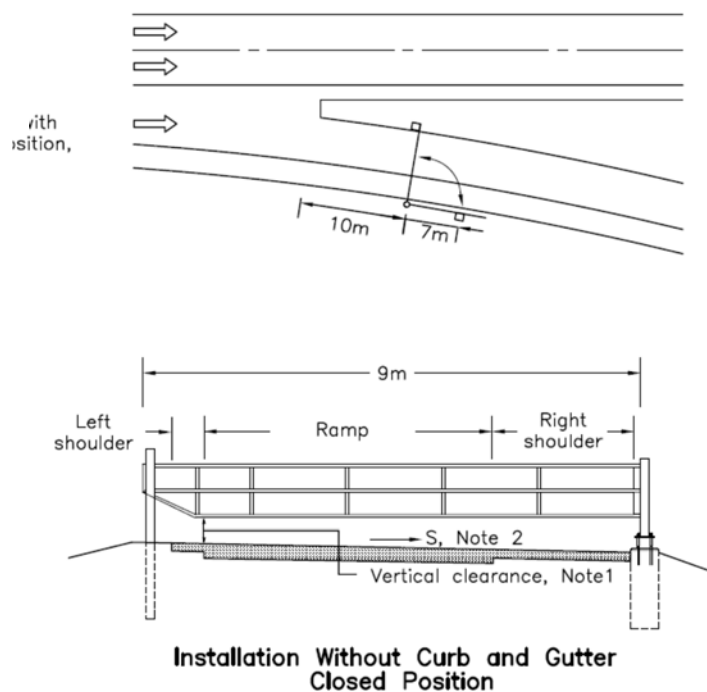

Figure 4-43-50: Breakaway Ramp Closure gate installed on ramp without curb. Gate shown in ramp closed position.

4.7 Culvert Ends

Exposed crossing culvert ends projecting beyond foreslopes within the desirable clear zone along roadways are considered to be obstacles with high severity indices. Figure 4-45-51 shows an exposed culvert end. Errant vehicles encroaching onto recoverable slopes and non-recoverable slopes can come to abrupt stops or rollover when encountering exposed crossing culvert ends or parallel culvert ends. Various grading design and safety end treatment alternatives are available to minimize probability of impacts by locating culvert ends beyond the desirable clear zone or modifying ends to make them traversable. These options should be considered and evaluated early during hydraulic design of culverts prior to finalizing the length of new culverts and culvert extensions to determine if alternative grading options and safety end treatments can result in a cost beneficial design without having to specify a barrier system to shield the culvert end.

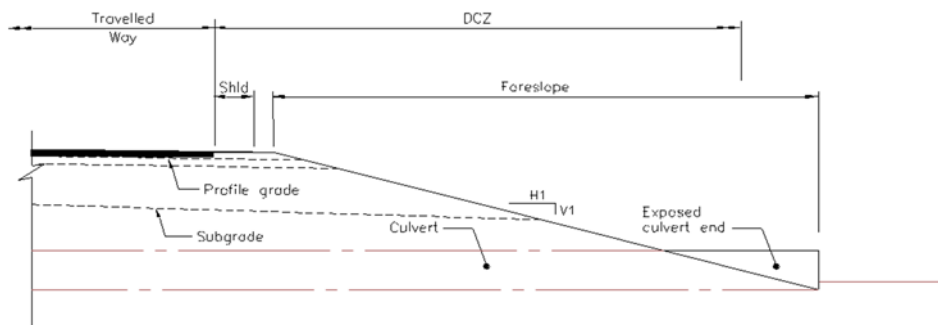
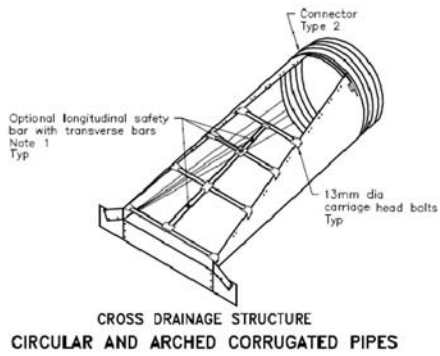
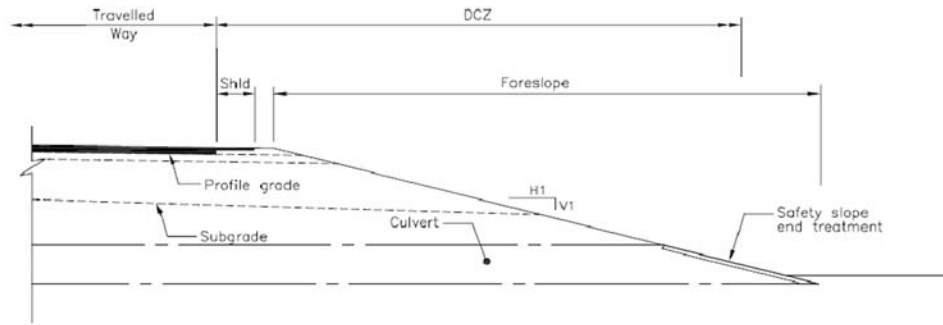

Figure 4-4451: Exposed Culvert End within Desirable Clear Zone

Steel safety slope end treatments that match 4H:1V and 6H:1V foreslopes as shown in Figure 4-46-52 are available for round culverts ranging in size from 300 mm to 1400 mm diameters, arched pipes up to 2130 mm spans with 1400 mm rise, and elliptical pipes up to 1930 mm spans with 1220 mm rise. For cross culverts with openings wider than 750 mm, longitudinal safety bars should be used. For parallel culverts, transverse bars should be used. Heavier longitudinal bars are used for concrete box culverts.

Another option is to use a headwall beyond the desirable clear zone and adjust the foreslope as shown in Figure 4-47-53. While this option results in a vertical drop off over top of the culvert and headwall, the safety benefits of the increased offset to the headwall versus an exposed end versus a relatively long barrier system in proximity to roadway needs to be analysed as part of a benefit cost evaluation.



Concrete Box

Figure 4-4552: Culvert End with Safety Slope End Treatment

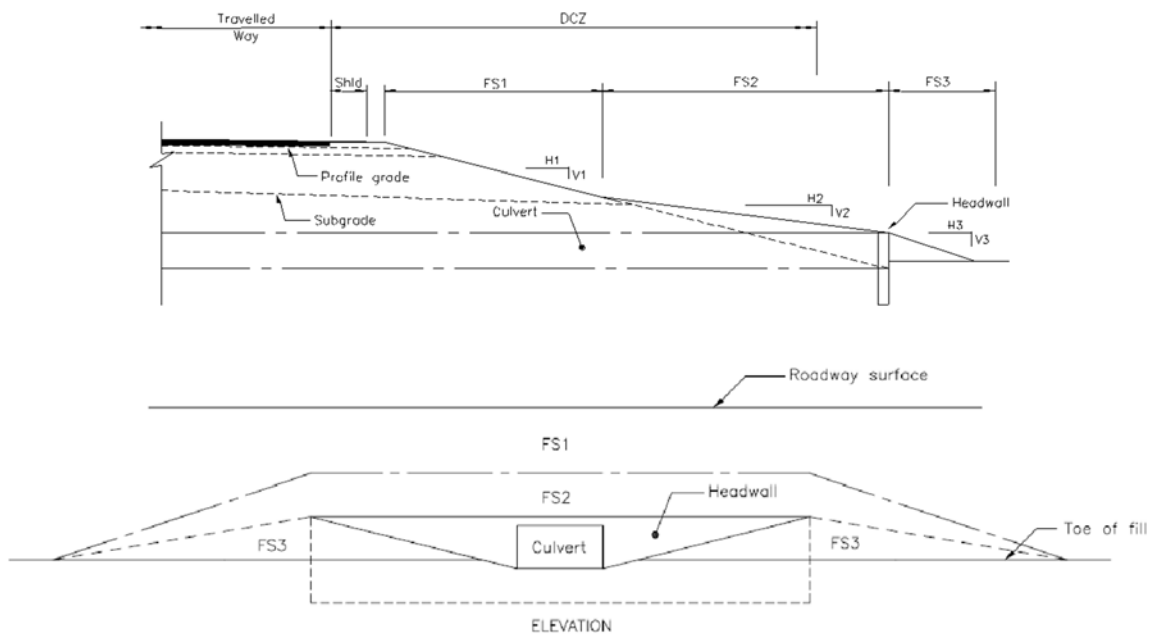

Figure 4-4653: Culvert End with Headwall

