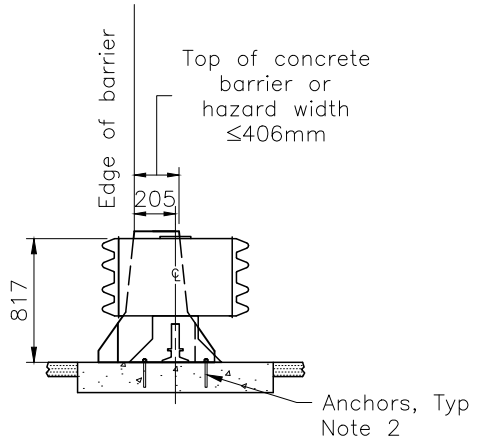
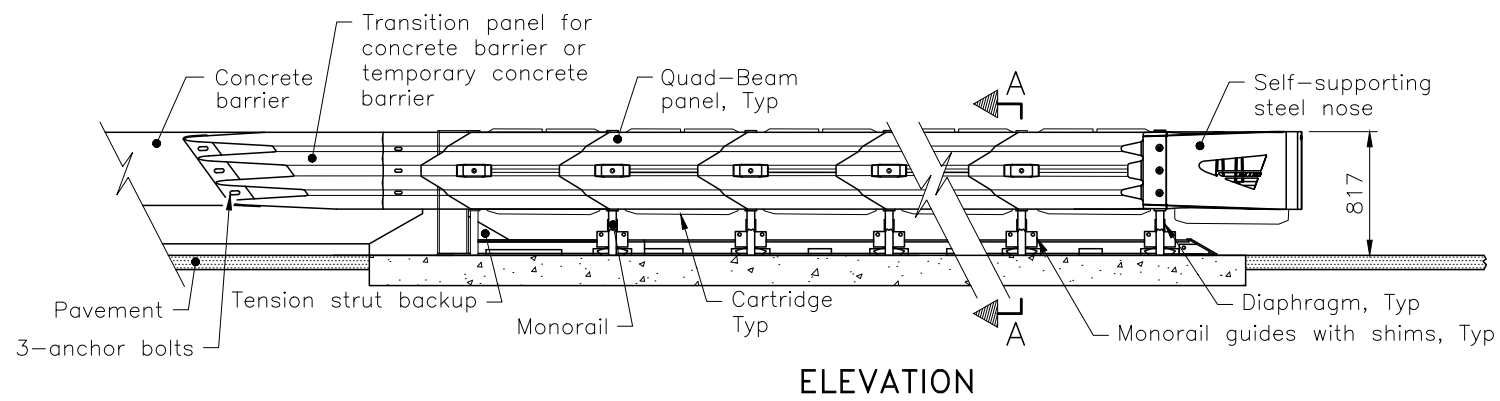

TABLE 1		
SYSTEM CONFIGURATION	TL-2	TL-3
M10 TYPE I CARTRIDGES FRONT REQ'D	3	4
M10 TYPE II CARTRIDGES REAR REQ'D	1	3
SYSTEM LENGTH	3960	6710



NOTES:

- 1 The system shall be anchored to a concrete pad as detailed in OPSD 923.001.
- 2 Anchors shall be according to the manufacturer's specifications, or manufacturer's accepted alternative.
- A Delineation shall be according to OPSD 984.204.
- B The system depicted here is a proprietary product.
- C System configuration meets AASHTO MASH TL-2 or TL-3 (Table 1).
- D All dimensions are in millimetres unless otherwise shown.

MINISTRY OF TRANSPORTATION ONTARIO DRAWING	September 2022	Rev	1
ENERGY ATTENUATOR, CRASH CUSHION QUADGUARD M10 SYSTEM INSTALLATION – PERMANENT BIDIRECTIONAL		----- ----- -----	
		MTOD – 923.199	